



SAXONY GRILL GAZEBO

Model # 2104617

Owner's Manual & Assembly Instructions

MANUFACTURED BY:
Backyard Discovery
3305 Airport Drive
Pittsburg, KS 66762
800-856-4445



GOCONFIGURE
Putting it all together for you

INSTALLATION SERVICES AVAILABLE!*

Need a helping hand?
Let our team of professionals handle the installation for you!

GOCONFIGURE
888-888-5424

*Installation services are only available to U.S. customers.

average 2 person assembly time



assembly time may vary based on skill level

Before you begin >>>

FOR QUICK & EASY ASSEMBLY
FIND 3D INSTRUCTIONS FOR THIS PRODUCT IN

BILT.

DOWNLOAD THE FREE APP

 GET IT ON Google Play

 Download on the App Store

For the most up to date assembly manual, to register your set, or to order replacement parts please visit www.backyarddiscovery.com

SAVE THIS ASSEMBLY MANUAL FOR FUTURE REFERENCE IN THE EVENT THAT YOU NEED TO ORDER REPLACEMENT PARTS.

Para obtener instrucciones en español, visite www.backyarddiscovery.com



GOCONFIGURE
Putting it all together for you

INSTALLATION SERVICES AVAILABLE!*

Need a helping hand?

Let our team of professionals handle the installation for you!

GOCONFIGURE
888-888-5424

**Installation services are only available
to U.S. customers.*

With Go Con! gure, we bring you 18 years of experience right to your doorstep. We service a wide array of indoor and outdoor recreation products that most consumers don't have the time or ability to deliver & install themselves.

We do the heavy lifting, so you don't have to!

-
- 18+ Years of Experience Servicing Big Box Retailers and Direct Consumers
 - Highly Skilled, Specialized, Courteous, Professional Service Technicians
 - Over 140,000 Installations Annually
 - White Glove Service

- Satisfaction Guarantee
 - Flexible Appointments, including weekends
 - Coverage across the nation
- Visit www.goconfigure.com for more info!**

**Installation services are only available to U.S. customers.*



The store where you made your purchase does not stock parts for this item.

If you have assembly questions or you are missing or have damaged parts, please call

1-800-856-4445

you can also visit www.backyarddiscovery.com

or e-mail customerservice@backyarddiscovery.com

Please have the following information ready when you make your call:

- Model Number of the product located on the front of the assembly manual
 - The item description and number from the parts list from the manual that was included in your box
-
- Read entire assembly manual, paying special attention to the important tips and safety information.
 - Ensure there are no missing pieces by first separating and identifying all parts.
 - Make sure to check packing material for small parts that may have fallen out during shipment.
 - Structures are not intended for public use. Any unintended use such as home child care, daycare center, faith center, government facility, home owner's associate, park or school will make the warranty of our product null & void.
 - This manual contains helpful information concerning assembly preparation, installation procedure and required maintenance.
 - Always keep safety in mind as your structure is being built.
 - Keep these instructions for future reference.



Please read entire booklet completely before beginning the assembly process

Please retain these instructions and your receipt for future reference. Keep them in a safe place where you can refer to them as needed. In order to provide you with the most efficient service, it is required that you provide us with the part numbers when ordering parts.

For Your Records:

Please take time and fill out the information below. This information will be needed for warranty issues.

Where Purchased: _____
 Date of Purchase: _____
 Installation Date: _____
 Installed by: _____
 Tracking Number: _____

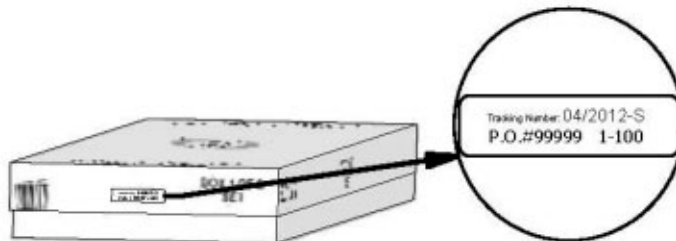

Tracking Number Reference Label

Tracking ID number on the carton and on the bottom of the vertical ID plate are included for tracking purposes associated with warranty claims.

This Limited Warranty by Backyard Discovery applies to products manufactured under the Backyard Discovery brand or its other brands including but not limited to Backyard Botanical, Adventure Playsets, and Leisure Time Products.

Backyard Discovery warrants that this product is free from defect in materials and workmanship for a period of one (1) year from the original date of purchase. This one (1) year warranty covers all parts including wood, hardware, and accessories. All wood carries a 5 year pro-rated warranty against rot and decay. Refer to the schedule below for charges associated with replacement of parts under this Limited Warranty. In addition, Backyard Discovery will replace any parts within the first 30 days from date of purchase found to be missing from or damaged in the original packaging.

This warranty applies to the original owner and registrant and is non-transferable. Regular maintenance is required to assure maximum life and performance of this product. Failure by the owner to maintain the product according to the maintenance requirements may void this warranty. Maintenance guidelines are provided in the Owner's Manual.

This Limited Warranty does not cover:

- Labor for any inspection
- Labor for replacement of any defective item(s)
- Incidental or consequential damages
- Cosmetic defects which do not affect performance or integrity of a part or the entire product
- Vandalism, improper use, failure due to loading or use beyond the capacities stated in the applicable Assembly Manual.
- Acts of nature including but not limited to wind, storms, hail, floods, excessive water exposure
- Improper installation including but not limited to installation on uneven, unlevel, or soft ground
- Minor twisting, warping, checking, or any other natural occurring properties of wood that do not affect performance or integrity

Backyard Discovery products have been designed for safety and quality. Any modifications made to the original product could damage the structural integrity of the unit leading to failure and possible injury. Modification voids any and all warranties and Backyard Discovery assumes no liability for any modified products or consequences resulting from failure of a modified product.

This product is warranted for RESIDENTIAL USE ONLY. Any unintended use such as home child care, daycare center, faith center, government facility, home owner's associate, park or school will make the warranty of our product null & void.

Pro Rated Part Replacement Schedule

<u>Product Age</u>	<u>Customer Pays</u>
All Parts	
0-30 days from date of purchase	\$0 and free shipping
31 days to 1 year	\$0 + S&H
Wood Rot and Decay Only	
1 year	\$0 and free shipping
2 year	20% + S&H
3 year	40% + S&H
4 year	60% + S&H
5 year	80% + S&H
Over 5 years	100% + S&H



WARNING

IT IS IMPORTANT TO CHECK AND TIGHTEN ALL HARDWARE AT THE BEGINNING AND DURING THE SEASON AS THEY MAY LOOSEN DUE TO WOOD EXPANSION AND CONTRACTION.

- **DO NOT climb or walk on the roof for any reason**
- **Requires two or more people to assemble safely**
- **Check for underground utilities before digging or driving stakes into the ground.**
- **Check carefully for overhead lines and ensure there is at least 6ft (2m) clearance from any overhead electrical wires.**
- **Permanent structures may require a building permit. As the purchaser and or installer of this product you are advised to consult local planning, zoning and building inspection departments for guidance on applicable building codes and/or zoning requirements.**
- Wood is NOT flame retardant and will burn. Grills, fire pits and chimineas are a fire hazard if place too close to your structure.
- Wear gloves to avoid injury during installation.
- During installation, follow all safety warnings provided with your tools and use safety glasses.
- Check all nuts and bolts twice monthly during the usage season and tighten as required.(But not so tight that you crack the wood) It is particularly important that this procedure be followed at the beginning of each season.
- Oil all metallic moving parts monthly during the usage period.
- Check all coverings for bolts and sharp edges twice monthly during usage season to be certain they are in place. Replace when necessary. It is especially important to do this at the beginning of each new season.
- For rusted areas on metallic members such as hinges, brackets, etc. sand and repaint, using a non lead-based paint meeting the requirements of Title 16 CRF Part 1303.
- Inspect wood parts monthly. The grain of the wood sometimes will lift in the dry season causing splinters to appear. Light sanding may be necessary to maintain a safe environment. Treating your Product with protection (sealant) after sanding will help prevent severe checking/ splitting and other weather damage.
- We have applied a waterborne translucent stain to your unit. This is done for color only. Once or twice a year, depending on your climate conditions, you must apply some type of protection (sealant) to the wood of your unit. Prior to the application of sealant, lightly sand any "rough" spots on your set. Please note this is a requirement of your warranty.

OWNERS SHALL BE RESPONSIBLE FOR MAINTAINING THE LEGIBILITY OF THE WARNING LABELS



Your Backyard Discovery structure is designed and constructed of quality materials. As with all outdoor products it will weather and wear. To maximize the enjoyment, safety and life of your structure it is important that you properly maintain it.

About Our Wood

Backyard Discovery uses 100% Cedar (C. Lanceolata) wood. Although we take great care in selecting the best quality lumber available, wood is still a product of nature and susceptible to weathering which can change the appearance of your set.

What causes weathering? Does it affect the strength of my product?

One of the main reasons for weathering is the effects of water (moisture); the moisture content of the wood at the surface is different than the interior of the wood. As the climate changes, moisture moves in or out of the wood, causing tension which can result in checking and or warping. You can expect the following due to weathering. These changes will not affect the strength of the product:

1. Checking is surface cracks in the wood along the grain. A post (4" x 4") will experience more checking than a board (1" x 4") because the surface and interior moisture content will vary more widely than in thinner wood.

2. Warping results from any distortion (twisting, cupping) from the original plane of the board and often happens from rapid wetting and drying of the wood.

3. Fading happens as a natural change in the wood color as it is exposed to sun-light and will turn grey over time.

How can I reduce the amount of weathering to wood product?

1. Your wood product is coated with a water-based stain. Sunlight will break down the coating, so we recommend applying a water repellent or stain on a yearly basis (see your local stain and paint supplier for a recommended product). You must apply some type of protection (sealant) to the wood of your product. **Please note this is a requirement of your warranty.** Most weathering is just the normal result of nature and will not affect safety. However if you are concerned that a part has experienced a severe weathering problem please call our customer service department for further assistance.

2. Inspect wood parts monthly. The grain of the wood sometimes will lift in the dry season causing splinters to appear. Light sanding may be necessary to maintain a safe environment. Treating your Product with protection (sealant) after sanding will help prevent severe checking/ splitting and other weather damage.



Protrusion Hazard

Incorrect

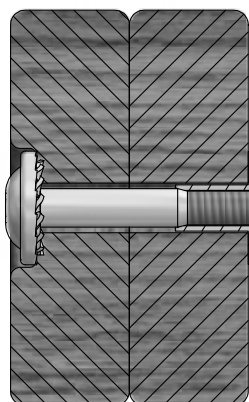

If you see exposed threads and your bolt protrudes beyond the T-Nut you may have over tightened the bolt or used incorrect hardware. If you've overtightened, remove the bolt and add washers to eliminate the protrusion.

Correct

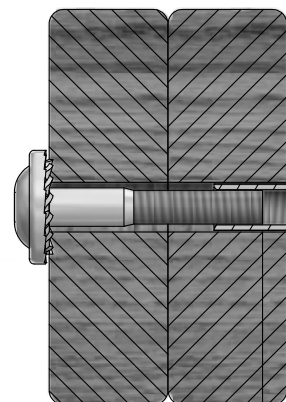

1/8"

Proper Hardware Assembly

Bolt and T-Nut Assembly

Tap T-nut into the provided hole. Insert your bolt through the lock washer and insert into the provided hole opposite from the T-Nut. Turn clockwise to thread into T-nut. Do not completely tighten until instructed.

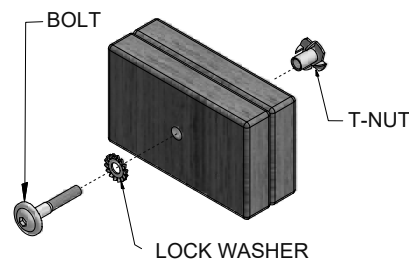

Bolt and Barrel Nut Assembly

Insert barrel nut through the lock washer and press the pair through the provided hole. Insert your bolt through the second lock washer and insert the pair into the provided hole opposite from the barrel nut. Turn clockwise to thread into the barrel nut. Do not completely tighten until instructed.

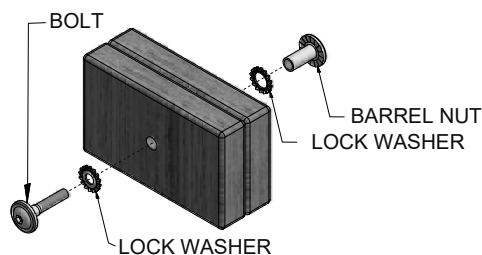

Lag Assembly

Normally there will be a pre-drilled pilot hole on assemblies that require a Lag Screw. If there is no pilot hole, line up the two boards as they are to be attached and use the factory drilled hole as a guide to drill another pilot hole into the adjoining board. This will keep the wood from splitting. Only a lock washer is required for steps with Lag Screws.

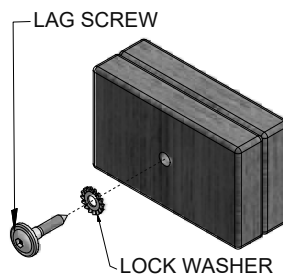



ASSEMBLY TIP:

Keep and eye out for these boxes which will contain helpful pictures and information making the assembly process as quick and painless as possible.

Sorting Wood

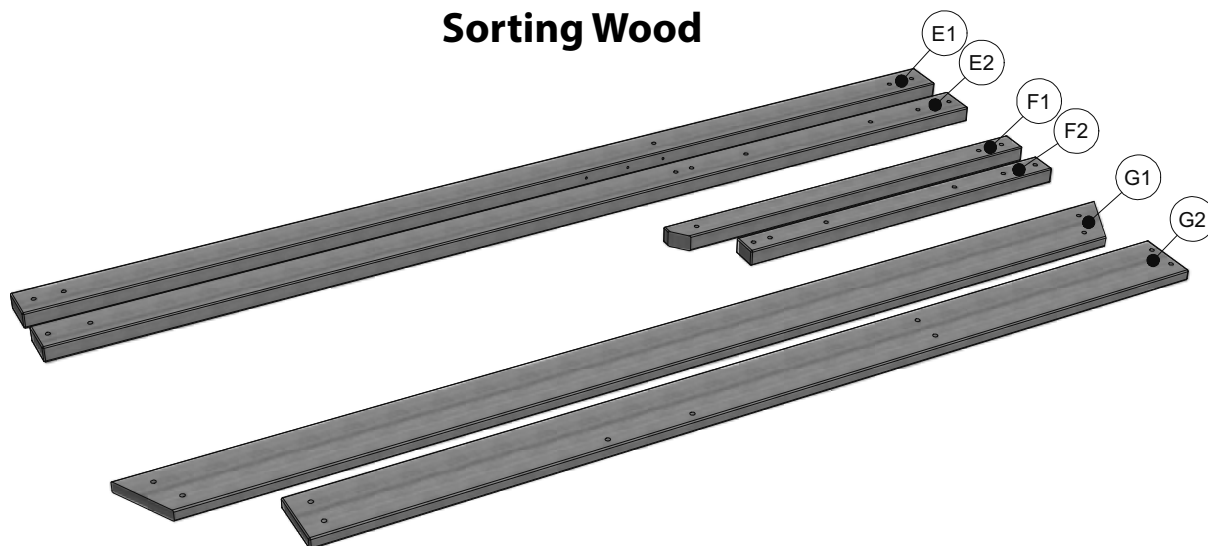

When removing the wood from the boxes we recommend arranging them by part number before you begin assembly. This will allow for faster assembly and easily identify any parts that may be missing or damaged.

Sorting Hardware

NUT BARREL
H100545



SCREW
H100695



T-NUT
H100699

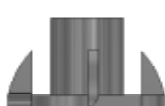

WASHER FLAT
H100706



BOLT HEX
H100716

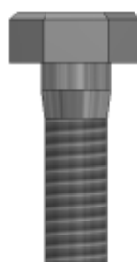

BOLT
H100718



SCREW PWH
H100742

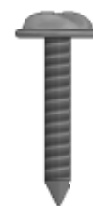

To help with assembly we recommend sorting your hardware bags with the seven digit alpha-numeric number printed on the bags or by hardware type (i.e. bolts, nuts, etc.). Organizing your hardware will make assembly easier.

Hardware Identification

Hardware bags are printed with a seven digit alpha-numeric part number. During assembly you only need to reference the last three digits of the part number as noted in each step. This will make finding the correct hardware easier.

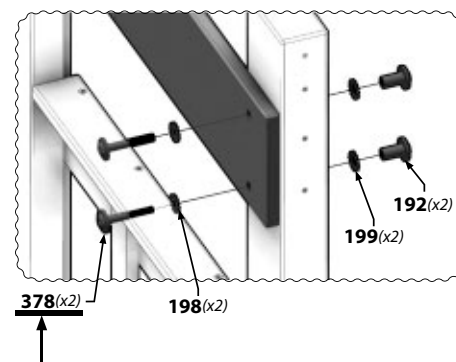
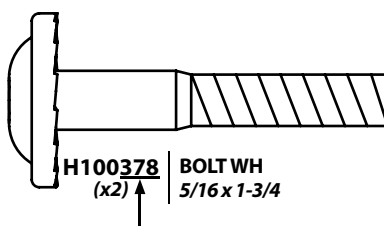

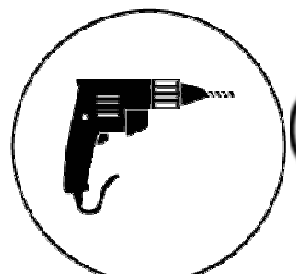
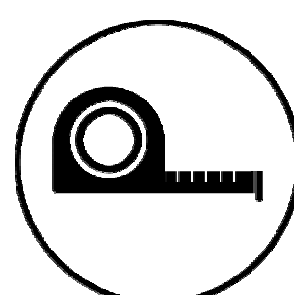
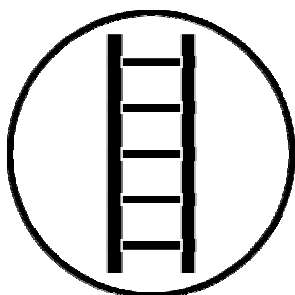
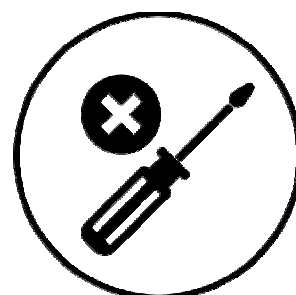
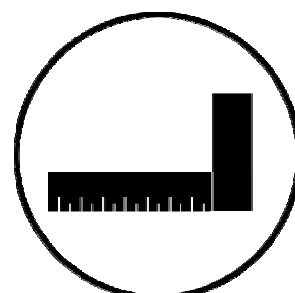
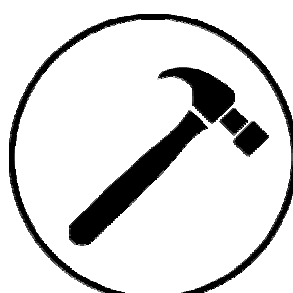
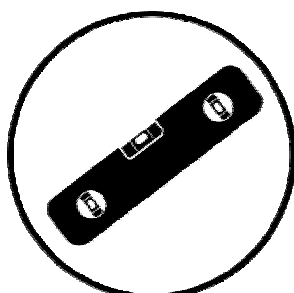
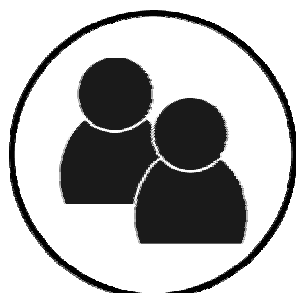

Icons and their uses you will see throughout this manual



You will need to make sure that your assembly is square before tightening your bolts.



When you see this icon you will need a socket wrench. The icons below show the size of attachments needed for assembly 1/2.



For proper assembly you will need to ensure that your structure is level before proceeding to the next step.

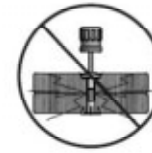

This icon warns you to not over tighten your bolts. This is to prevent structural damage and also splintering your wood.



Some steps in the assembly process will require an extra set of hands. Make sure you have a helper available.



A ladder will be needed for assembly. Do NOT stand on the set when it is incomplete, unstable, and not anchored. Failure to do so may result in injury.



This icon shows the size of an open ended wrench. Using the wrench as the fraction bar.



This icon will show you what drill attachments are needed. For this example you will need a Phillips head attachment and 3/8 drill bit.



It is critically important that you start with square and level footings, concrete pad or deck to attach your structure

- Pay close attention to the items needed for each step. Make sure you are using the correct hardware for each step. Using incorrect hardware may result in improper assembly
- Remember to double check for underground utilities and overhead electrical lines

Post mounts are provided with your structure which allows you to permanently install your structure to a pre-existing or new wood or concrete surface.

- The hardware to attach the post mounts to the structure is included.
- The hardware to mount the structure permanently to a concrete surface is included.
- The hardware to mount the structure permanently to a wood deck is NOT included and will need to be purchased separately. You must ensure there is ample structural support under the deck before permanently attaching.

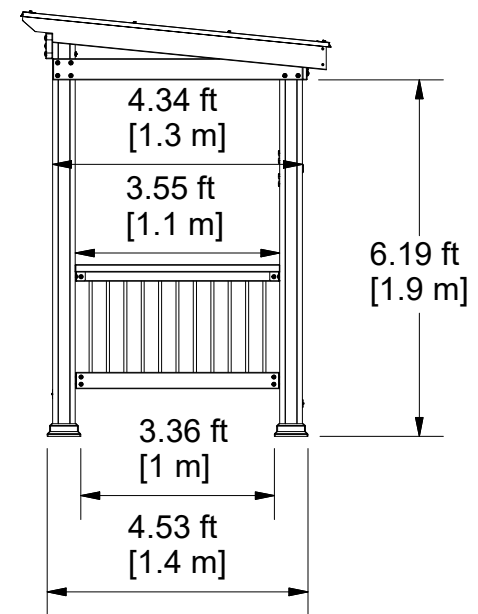
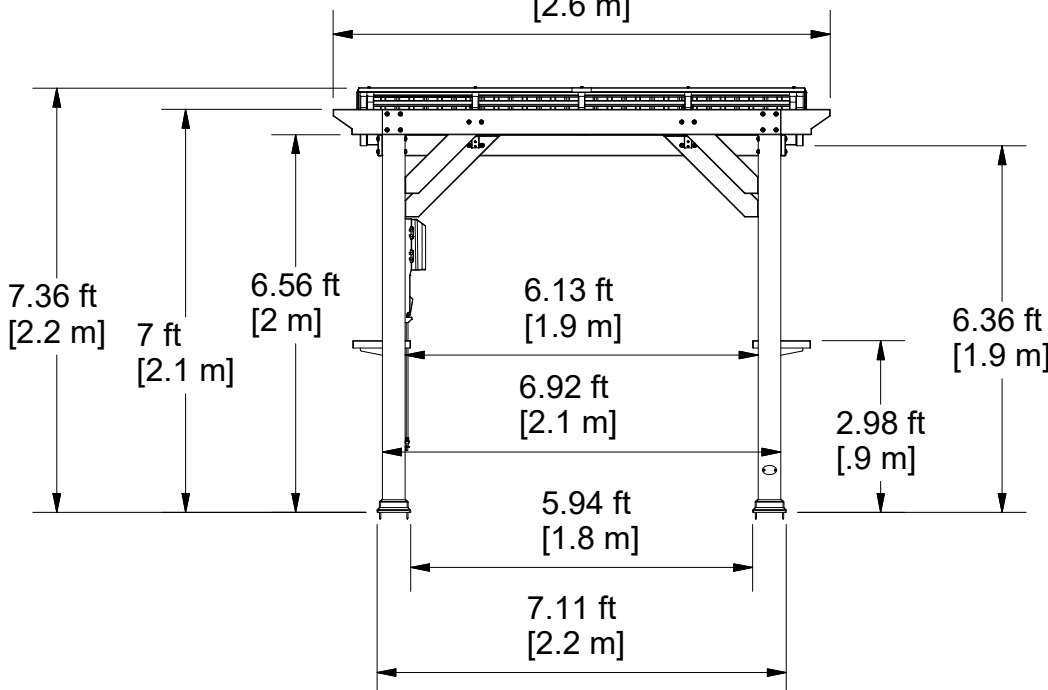
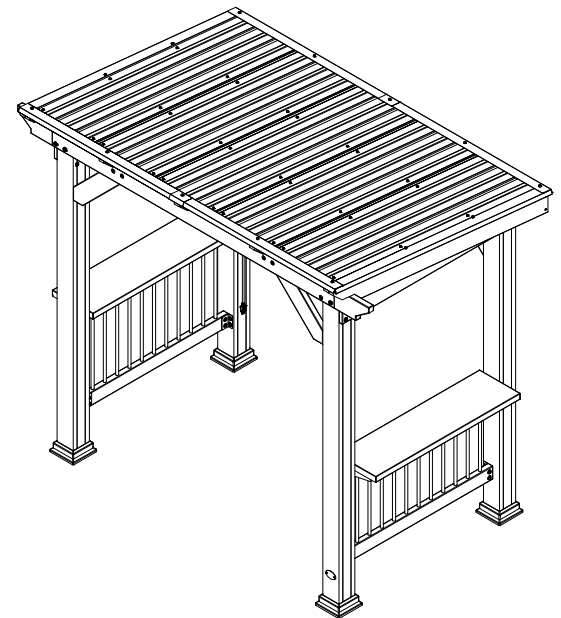
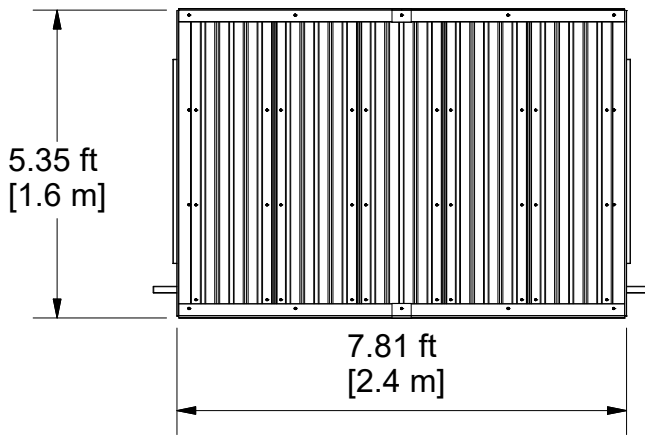



Wood Components (Not to Scale)



D1 | JOIST END - W4L14097
(x1) | 1 3/8"x5 1/4"x15" (36x134x381)

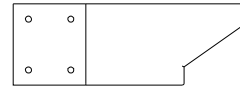

D2 | JOIST END - W4L14098
(x1) | 1 3/8"x5 1/4"x15" (36x134x381)



D3 | JOIST - W4L14099
(x1) | 1 1/2"x5 1/2"x83" (36x134x2108)

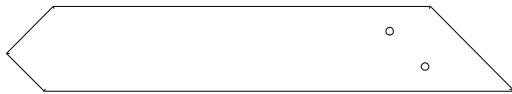

D4 | CORBEL - W4L14100
(x2) | 1 3/8"x4 3/8"x26 1/2" (36x112x673)

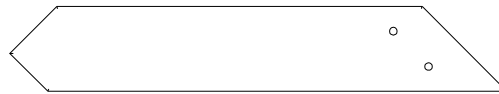

D5 | CORBEL - W4L14970
(x2) | 1 3/8"x4 3/8"x25 7/8" (36x112x657)

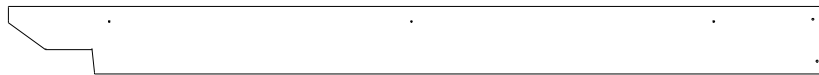

D6 | BEAM - W4L14107
(x1) | 1 3/8"x5 1/4"x64" (36x134x1626)



D8 | BEAM - W4L14345
(x1) | 1 3/8"x5 1/4"x64" (36x134x1626)

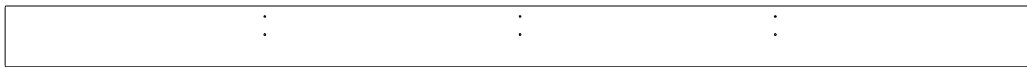

D7 | BEAM - W4L14110
(x1) | 1 3/8"x5 1/4"x89 1/2" (36x134x2272)



E1 | RAFTER - W4L14111
(x2) | 1 3/8"x3 3/8"x62 3/8" (36x86x1585)

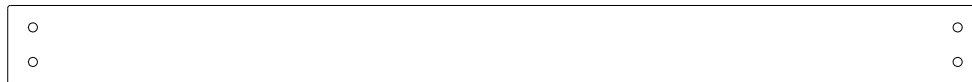

E2 | RAIL - W4L14317
(x4) | 1 1/2"x3 1/2"x42 1/2" (36x86x1076)



E3 | RAFTER - W4L14971
(x1) | 1 3/8"x3 3/8"x62 3/8" (36x86x1585)



Wood Components (Not to Scale)

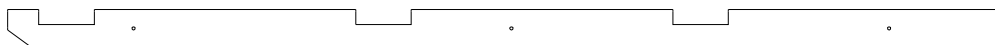

F1 | RAFTER - W4L14108
(x2) | 1 7/16"x2 3/8"x62 5/16" (36x60x1582)



H2 | PURLIN - W4L14109
(x3) | 1"x3 3/8"x89 1/2" (24x86x2272)



Q1 | RAIL - W4L14101
(x2) | 1"x4 1/2"x52" (24x112x1322)



Q2 | RAIL - W4L14102
(x1) | 1"x4 1/2"x85" (24x112x2156)



P1 | POST - W2A03094
(x1) | 4 3/4"x4 3/4"x78 1/4" (120x120x1987)



P2 | POST - W2A03095
(x1) | 4 3/4"x4 3/4"x83 1/2" (120x120x2121)



P3 | POST - W2A03096
(x1) | 4 3/4"x4 3/4"x78 1/4" (120x120x1987)



P4 | POST - W2A03097
(x1) | 4 3/4"x4 3/4"x83 1/2" (120x120x2121)



Hardware Components

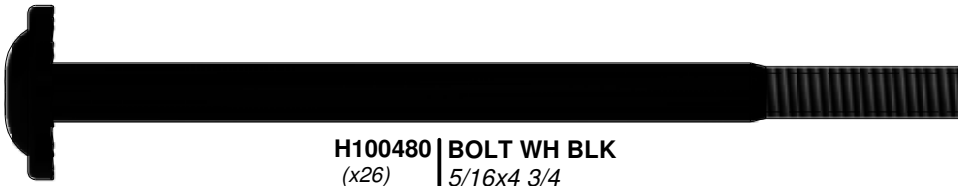

H100480 | BOLT WH BLK
(x26) | 5/16x4 3/4

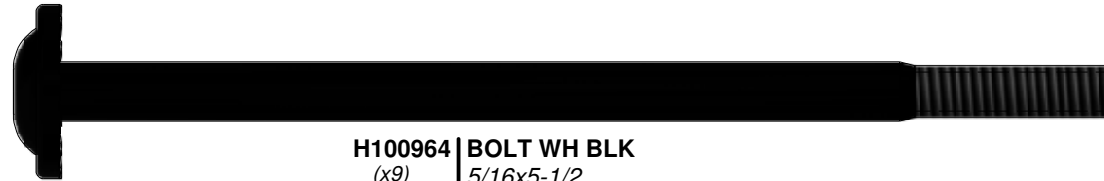

H100964 | BOLT WH BLK
(x9) | 5/16x5-1/2



H100205 | BOLT WH BLK
(x4) | 5/16x2-1/4



H100457 | BOLT WH BLK
(x4) | 5/16x2



H100471 | LAG SCREW WH BLK
(x26) | 5/16x1 1/2



H100459 | BOLT WH BLK
(x18) | 5/16x1 1/4



H100469 | NUT BARREL WH BLK
(x18) | 5/16x5/8



H100198 | WASHER LOCK EXT BLK
(x44) | 8x19



H100199 | WASHER LOCK EXT BLK
(x52) | 12x19



H100405 | WASHER LOCK EXT BLK
(x4) | 6x15

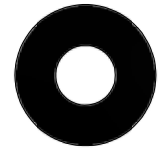

H100630 | WASHER FLAT BLK
(x22) | 8x19



H100792 | LAG SCREW WH BLK
(x4) | 1/4x3



H100192 | NUT BARREL WH BLK
(x9) | 5/16x7/8



H100193 | NUT BARREL WH BLK
(x34) | 5/16x1-1/2



H100488 | BOLT WH BLK
(x4) | 1/4x2

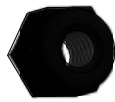

H100653 | NUT LOCK BLK
(x4) | 1/4



H101008 | SCREW CONFIRMAT BLK
(x11) | 7x3



H100201 | SCREW PFH BLK
(x7) | 8x2-1/2



H100392 | SCREW PWH BLK
(x13) | 8x3/4

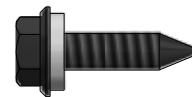

H100833 | SCREW WOODGRIP
(x44) | 10x3/4



H100382 | SCREW PFH BLK
(x16) | 8x1 3/4



H100120 | SCREW CONCRETE ANCHOR
(x18) | 1/4x2

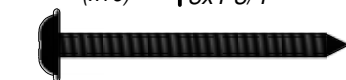

H100823 | SCREW PWH BLK
(x9) | 8x1-1/2



H100759 | SCREW TAPPING
(x15) | 1/4x3/4



Accessory Components (Not to Scale)

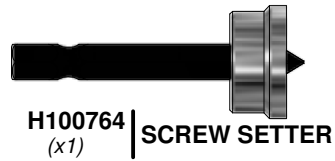

H100764 | SCREW SETTER
(x1)



H100147 | TORX BIT
(x2) | T-30



A100042 | TORX BIT
(x2) | T-40



H100114 | TORX WRENCH
(x2) | T-30

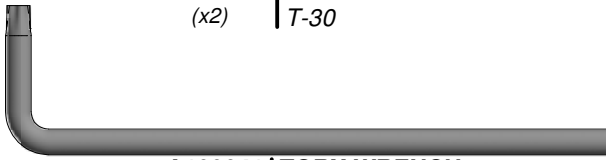

A100041 | TORX WRENCH
(x2) | T-40



A100241 | BYD ID TAG
(x1)



A100314 | "A" REVISION TAG
(x1)

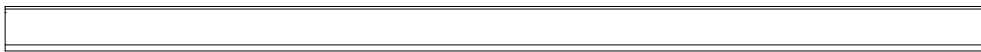

A4M01162 | ROOF EDGE TRIM
(x2)

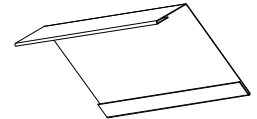

A4M00983 | ROOF EDGE TRIM SPLICE
(x2)

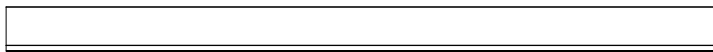

A4M01160 | ROOF EDGE TRIM
(x4)

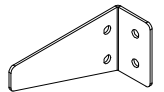

A4M01224 | L BRACKET
(x2)

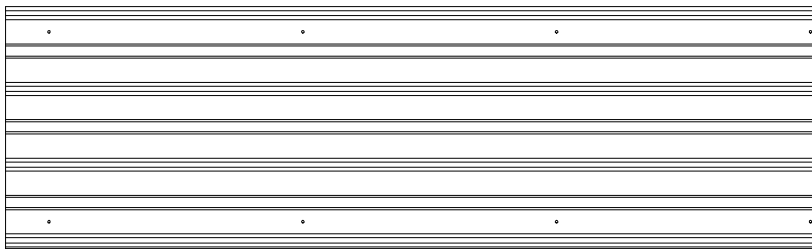

A4M01227 | 29GA STEEL SHEETING
(x5)

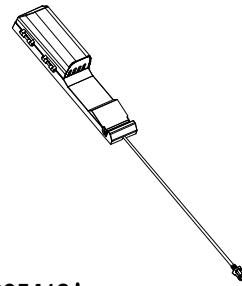

9205413 | ELECTRICAL ENCLOSURE
(x1)

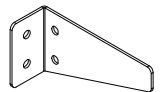

A4M01223 | L BRACKET
(x2)

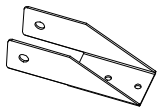

A4M01228 | RAFTER BRACKET
(x4)



A4M01225 | METAL TUBE
(x22)

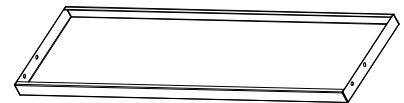

A4M01210 | TABLE
(x2)

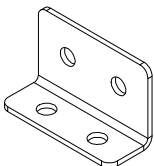

A4M00855 | L BRACKET 51x32x82x3.175
(x8)

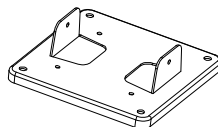

A4M01209 | FOOT BASE
(x4)

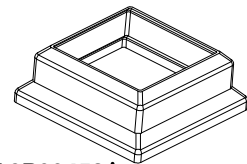

A6P00452 | FOOT BASE COVER
(x4)



STEP 1



P1 | PERGOLA POST - W2A03094
(x1) | 4 3/4"x4 3/4"x78 1/4" (120x120x1987)



P2 | PERGOLA POST - W2A03095
(x1) | 4 3/4"x4 3/4"x83 1/2" (120x120x2121)



P3 | PERGOLA POST - W2A03096
(x1) | 4 3/4"x4 3/4"x78 1/4" (120x120x1987)

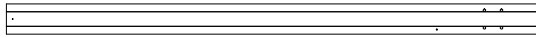

P4 | PERGOLA POST - W2A03097
(x1) | 4 3/4"x4 3/4"x83 1/2" (120x120x2121)



H100823 | SCREW PWH BLK
(x8) | 8x1-1/2

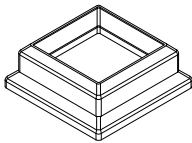

A6P00452 | FOOT BASE COVER
(x4)

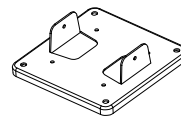

A4M01209 | FOOT BASE
(x4)



TIP:

FOR EASE OF ASSEMBLY WE RECOMMEND USING SAW HORSES FOR STEPS 1 THROUGH 4.

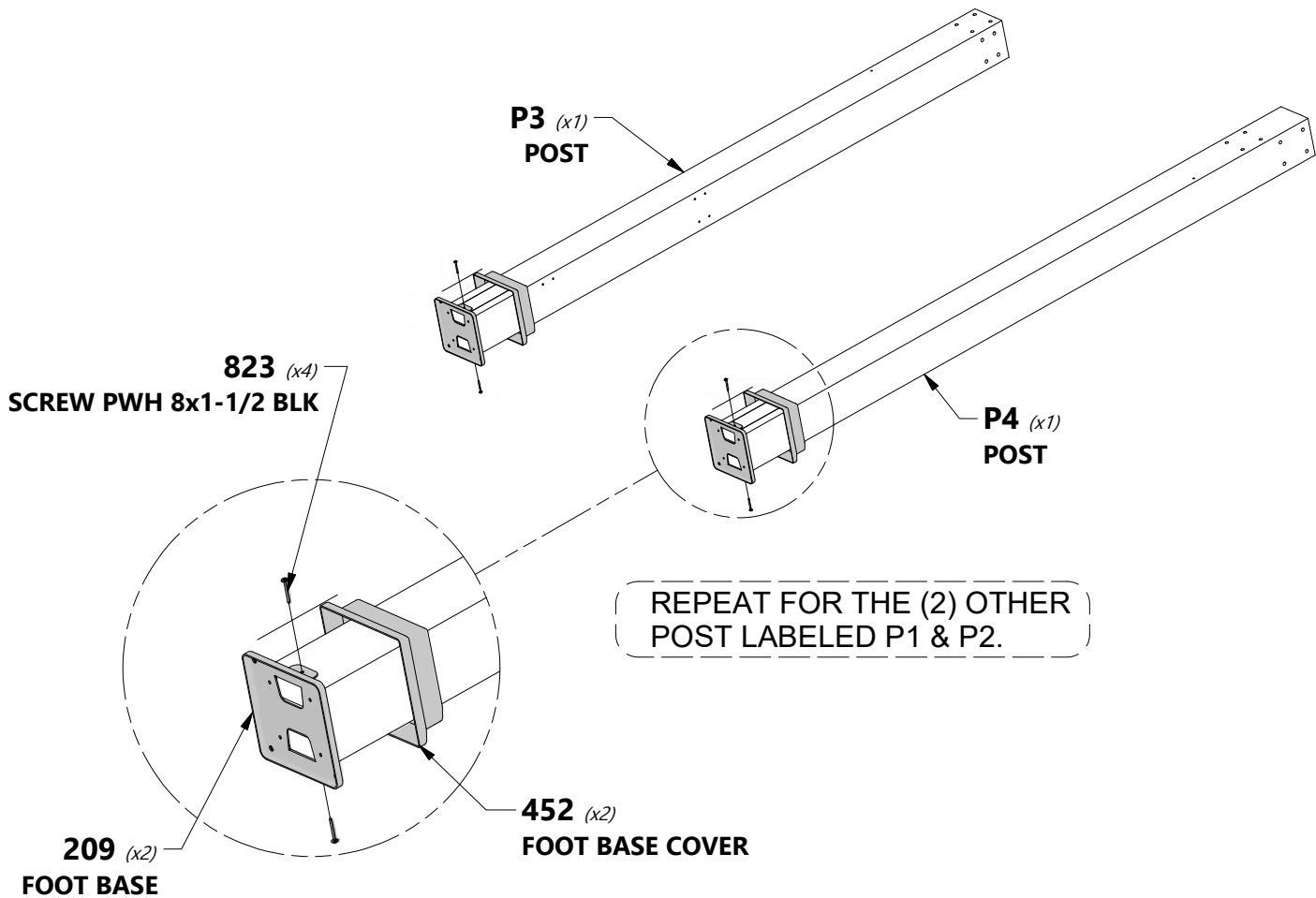



STEP 2

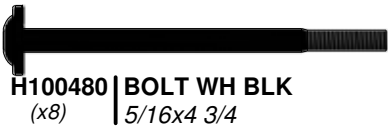

H100480 | BOLT WH BLK
(x8) | 5/16x4 3/4



H100193 | NUT BARREL WH BLK
(x8) | 5/16x1-1/2



H100459 | BOLT WH BLK
(x4) | 5/16x1 1/4



H100199 | WASHER LOCK EXT BLK
(x12) | 12x19



H100471 | LAG SCREW WH BLK
(x4) | 5/16x1 1/2



H100469 | NUT BARREL WH BLK
(x4) | 5/16x5/8



H100198 | WASHER LOCK EXT BLK
(x8) | 8x19



Q1 | RAIL - W4L14101
(x1) | 1"x4 1/2"x52" (24x112x1322)

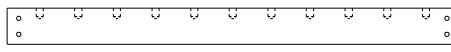

E2 | RAIL - W4L14317
(x1) | 1 1/2"x3 1/2"x42 1/2" (36x86x1076)

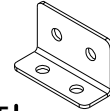

A4M00855 | L BRACKET 51x32x82x3.175
(x2)

HAND TIGHTEN ONLY. DO NOT TIGHTEN THIS CONNECTION UNTIL TABLE IS INSTALLED.

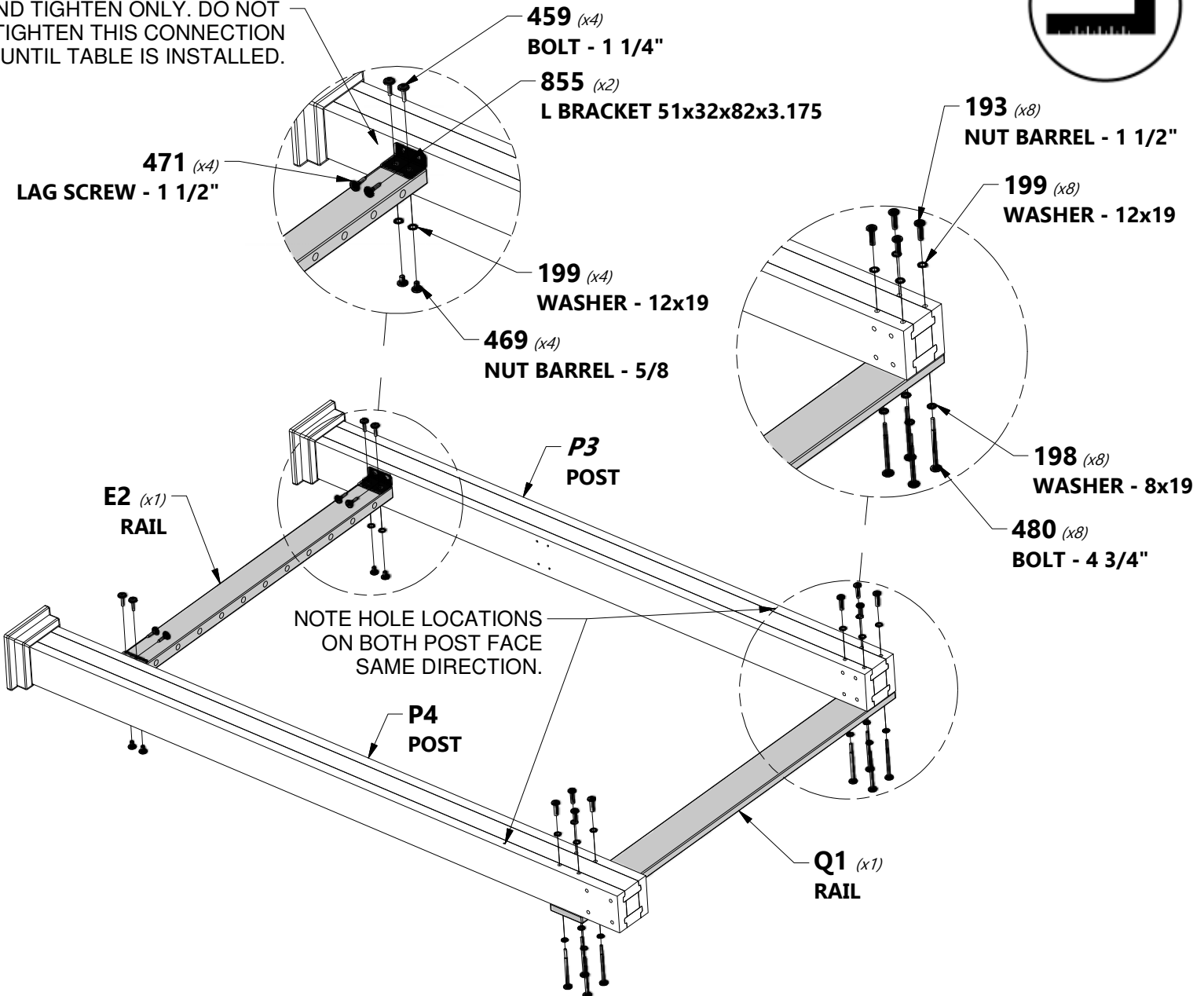



STEP 3



H100480 | BOLT WH BLK
(x8) | 5/16x4 3/4



H100193 | NUT BARREL WH BLK
(x8) | 5/16x1-1/2



H100459 | BOLT WH BLK
(x4) | 5/16x1 1/4



H100199 | WASHER LOCK EXT BLK
(x12) | 12x19



H100471 | LAG SCREW WH BLK
(x4) | 5/16x1 1/2



H100469 | NUT BARREL WH BLK
(x4) | 5/16x5/8



H100198 | WASHER LOCK EXT BLK
(x8) | 8x19



Q1 | RAIL - W4L14101
(x1) | 1"x4 1/2"x52" (24x112x1322)

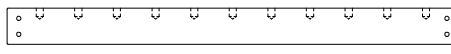

E2 | RAIL - W4L14317
(x1) | 1 1/2"x3 1/2"x42 1/2" (36x86x1076)

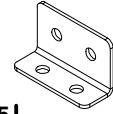

A4M00855 | L BRACKET 51x32x82x3.175
(x2)

HAND TIGHTEN ONLY. DO NOT TIGHTEN THIS CONNECTION UNTIL TABLE IS INSTALLED.

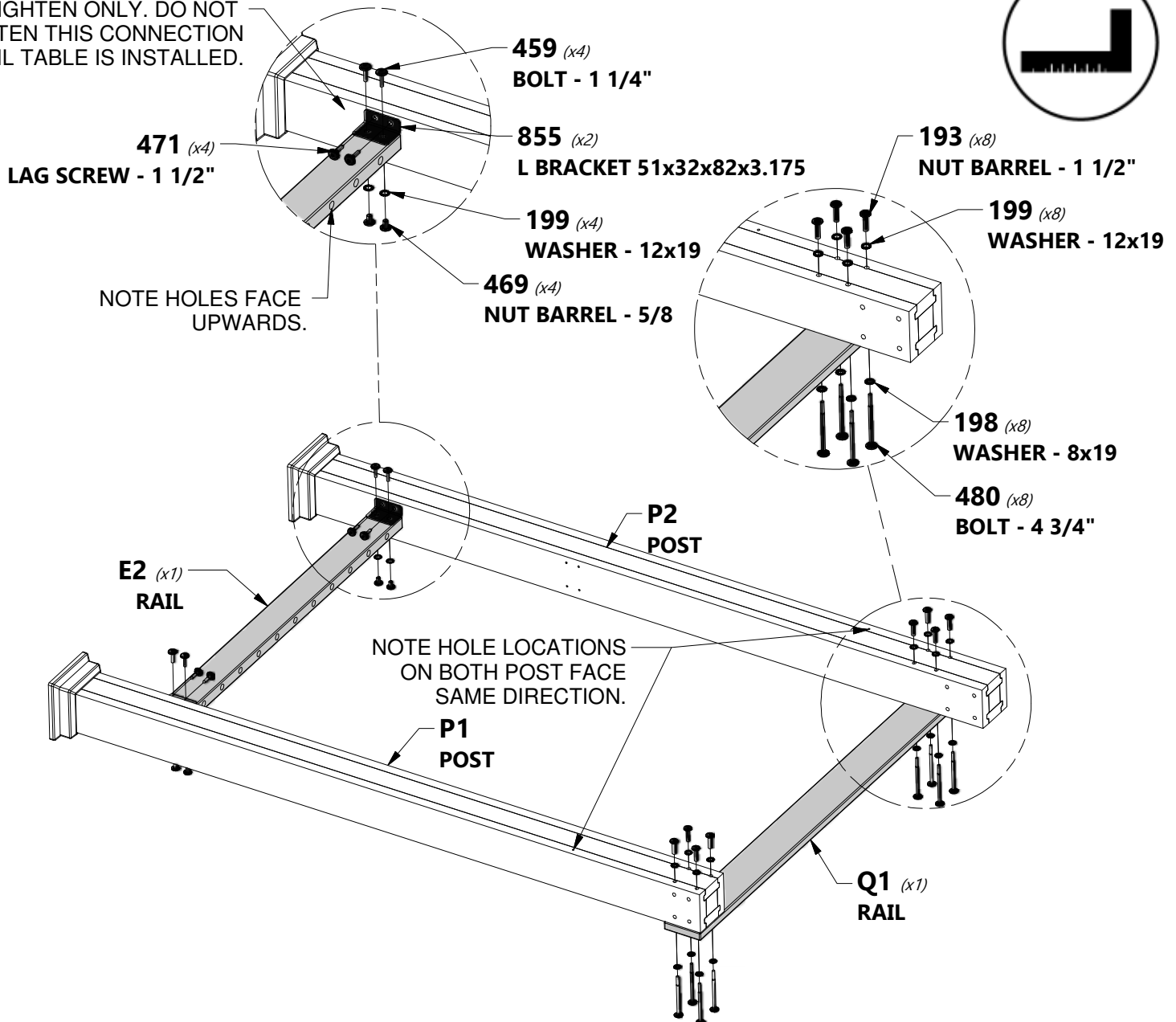



STEP 4



D3 | JOIST - W4L14099
(x1) | 1 1/2"x5 1/2"x83" (36x134x2108)



D4 | CORBEL - W4L14100
(x2) | 1 3/8"x4 3/8"x26 1/2" (36x112x673)



H100205 | BOLT WH BLK
(x4) | 5/16x2-1/4



H100192 | NUT BARREL WH BLK
(x4) | 5/16x7/8



H100198 | WASHER LOCK EXT BLK
(x4) | 8x19



H100199 | WASHER LOCK EXT BLK
(x4) | 12x19

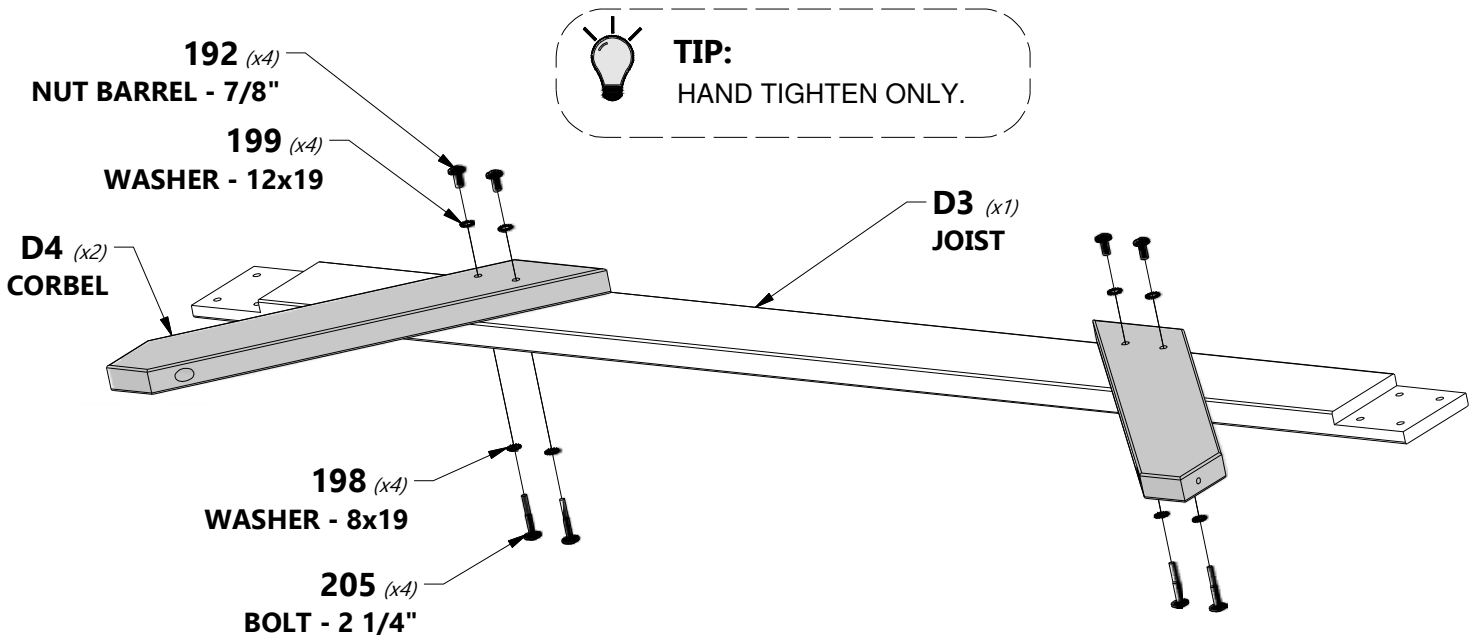



STEP 5

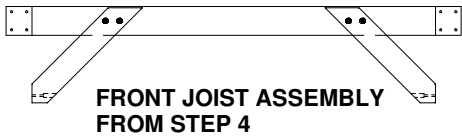

FRONT JOIST ASSEMBLY FROM STEP 4



D1 | JOIST END - W4L14097
(x1) | 1 3/8"x5 1/4"x15" (36x134x381)



D2 | JOIST END - W4L14098
(x1) | 1 3/8"x5 1/4"x15" (36x134x381)



H100964 | BOLT WH BLK
(x8) | 5/16x5-1/2



H100193 | NUT BARREL WH BLK
(x8) | 5/16x1-1/2



H100198 | WASHER LOCK EXT BLK
(x8) | 8x19



H100792 | LAG SCREW WH BLK
(x2) | 1/4x3



H100405 | WASHER LOCK EXT BLK
(x2) | 6x15



H100199 | WASHER LOCK EXT BLK
(x8) | 12x19

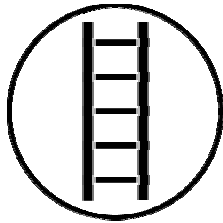
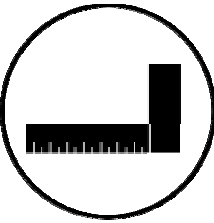
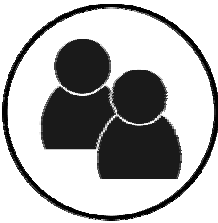

NOTE LAP ORIENTATION

FRONT JOIST ASSEMBLY

193 (x8) NUT BARREL - 1 1/2"

199 (x8) WASHER - 12x19

198 (x8) WASHER - 8x19

964 (x8) BOLT - 5-1/2"

D1 (x1) JOIST END

D2 (x1) JOIST END

405 (x2) WASHER - 6x15

792 (x2) LAG SCREW - 3"

NOTE: TALLER POST ARE LOCATED ON FRONT SIDE OF THE ASSEMBLY.



STEP 6

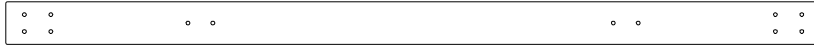

Q2 | RAIL - W4L14102
(x1) | 1"x4 1/2"x85" (24x112x2156)



D5 | CORBEL - W4L14970
(x2) | 1 3/8"x4 3/8"x25 7/8" (36x112x657)



H100480 | BOLT WH BLK
(x8) | 5/16x4 3/4



H100193 | NUT BARREL WH BLK
(x8) | 5/16x1-1/2



H100198 | WASHER LOCK EXT BLK
(x12) | 8x19



H100457 | BOLT WH BLK
(x4) | 5/16x2



H100199 | WASHER LOCK EXT BLK
(x12) | 12x19



H100792 | LAG SCREW WH BLK
(x2) | 1/4x3



H100192 | NUT BARREL WH BLK
(x4) | 5/16x7/8



H100405 | WASHER LOCK EXT BLK
(x2) | 6x15

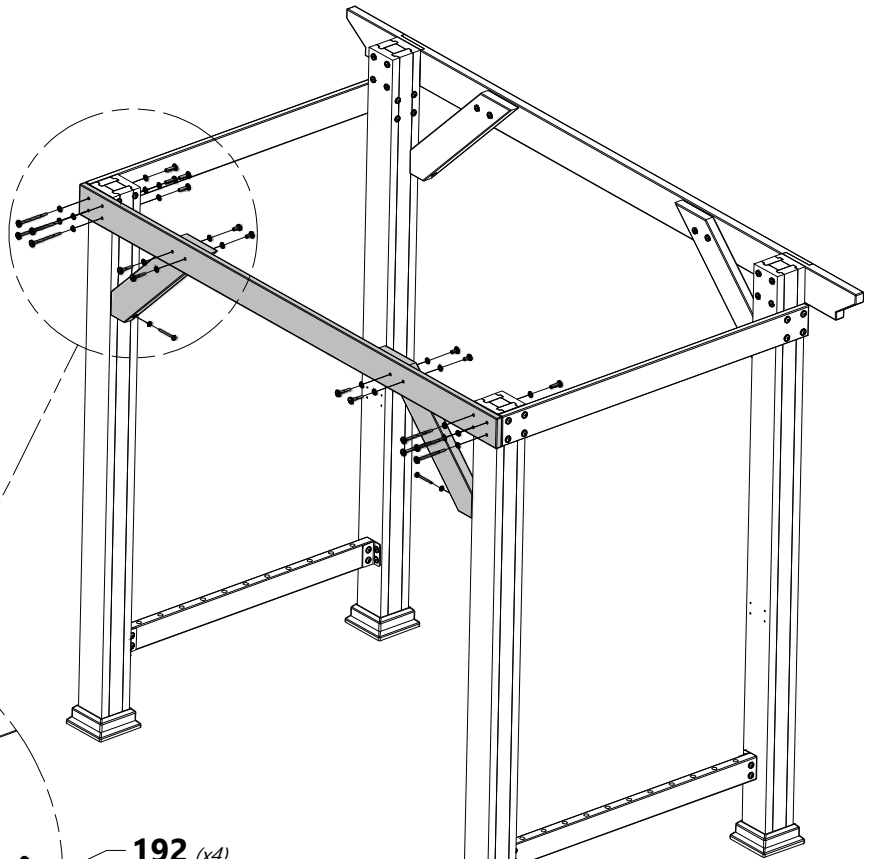
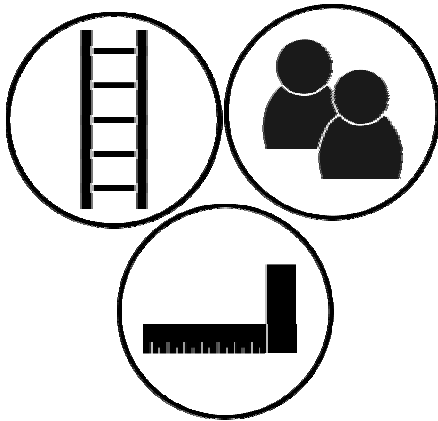

193 (x8)
NUT BARREL - 1 1/2"

199 (x8)
WASHER - 12x19

198 (x8)
WASHER - 8x19

480 (x8)
BOLT - 4 3/4"

192 (x4)
NUT BARREL - 7/8"

199 (x4)
WASHER - 12x19

Q2 (x1)
RAIL

198 (x4)
WASHER - 8x19

457 (x4)
BOLT - 2"

405 (x2)
WASHER - 6x15

792 (x2)
LAG SCREW - 3"



STEP 7

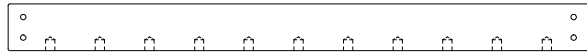

E2 | RAIL - W4L14317
(x2) | 1 1/2"x3 1/2"x42 1/2" (36x86x1076)

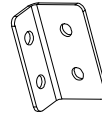

A4M00855 | L BRACKET 51x32x82x3.175
(x4)

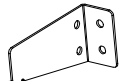

A4M01224 | L BRACKET
(x2)



H100459 | BOLT WH BLK
(x8) | 5/16x1 1/4



H100469 | NUT BARREL WH BLK
(x8) | 5/16x5/8

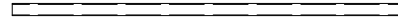

A4M01225 | METAL TUBE
(x22)

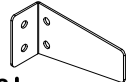

A4M01223 | L BRACKET
(x2)

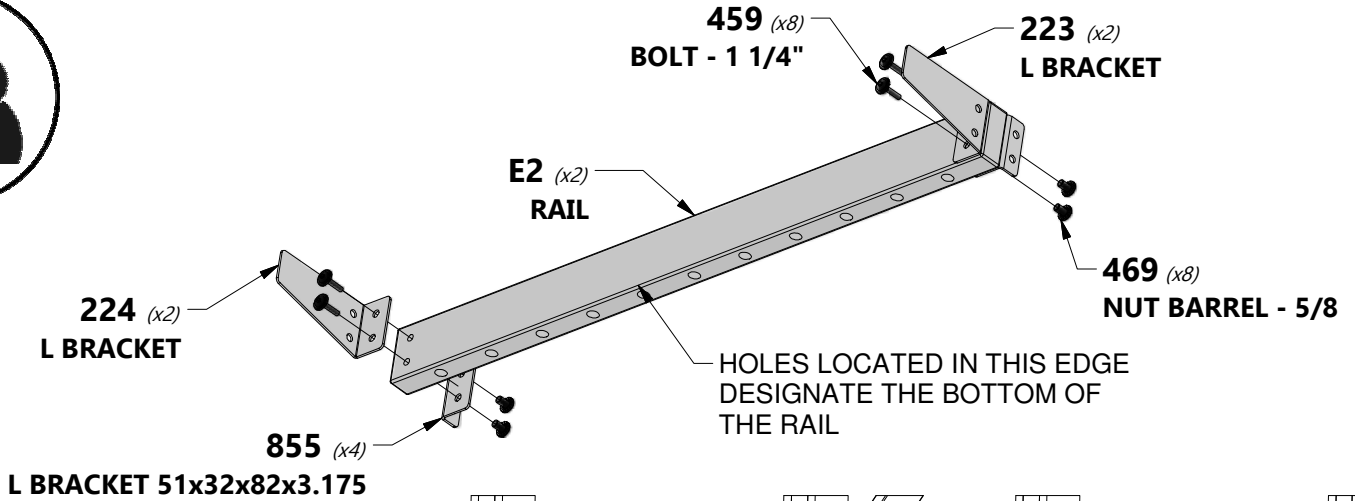
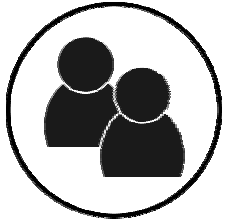

RAIL ASSEMBLIES FROM ABOVE

NOTE LARGER L BRACKETS FACE TOWARDS OUTSIDE.

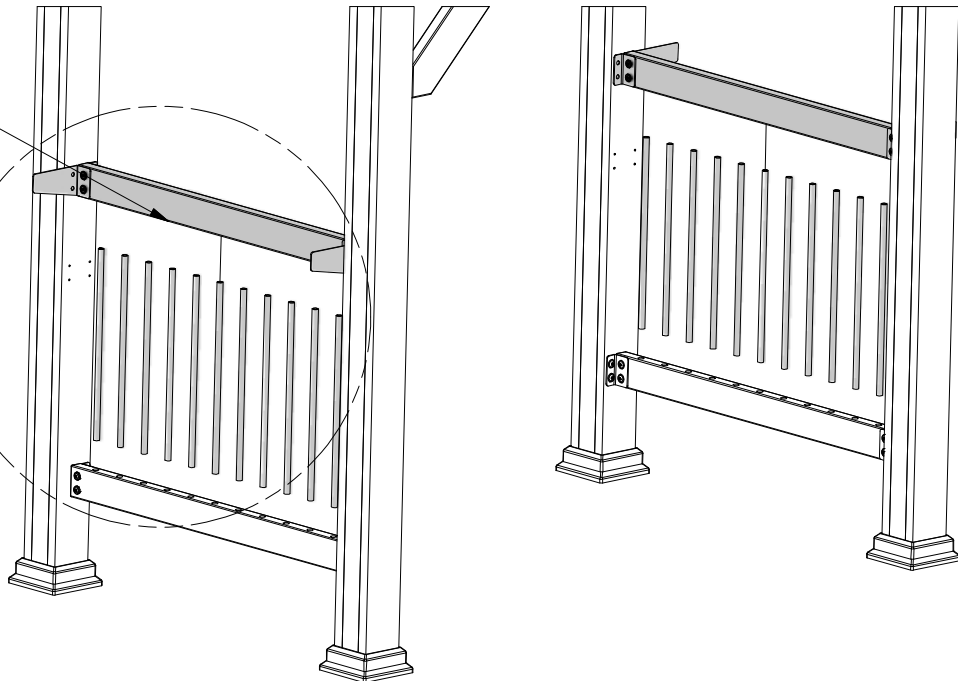

225 (x22) | METAL TUBE

PLACE RODS INTO BOTTOM BOARD ON UPRIGHT. PLACE E2 ON TOP. SECURE RODS BETWEEN BOTH BOARDS.



STEP 8



H100471 | LAG SCREW WH BLK
(x8) | 5/16x1 1/2

REPEAT STEP FOR OPPOSITE SIDE

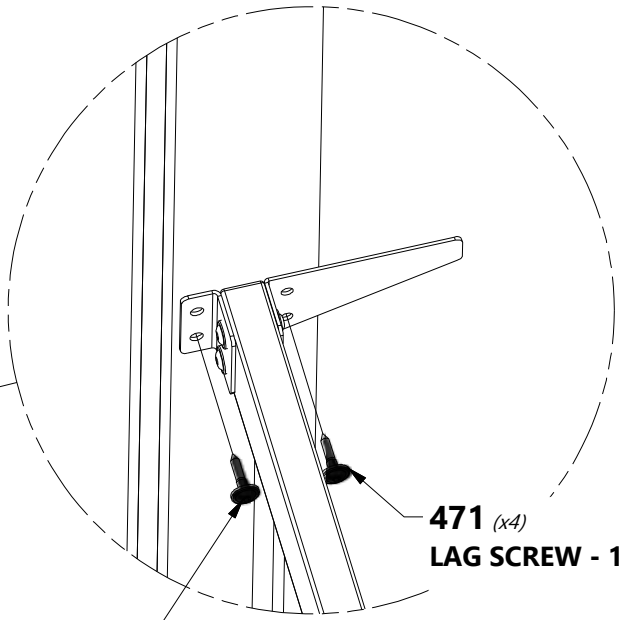
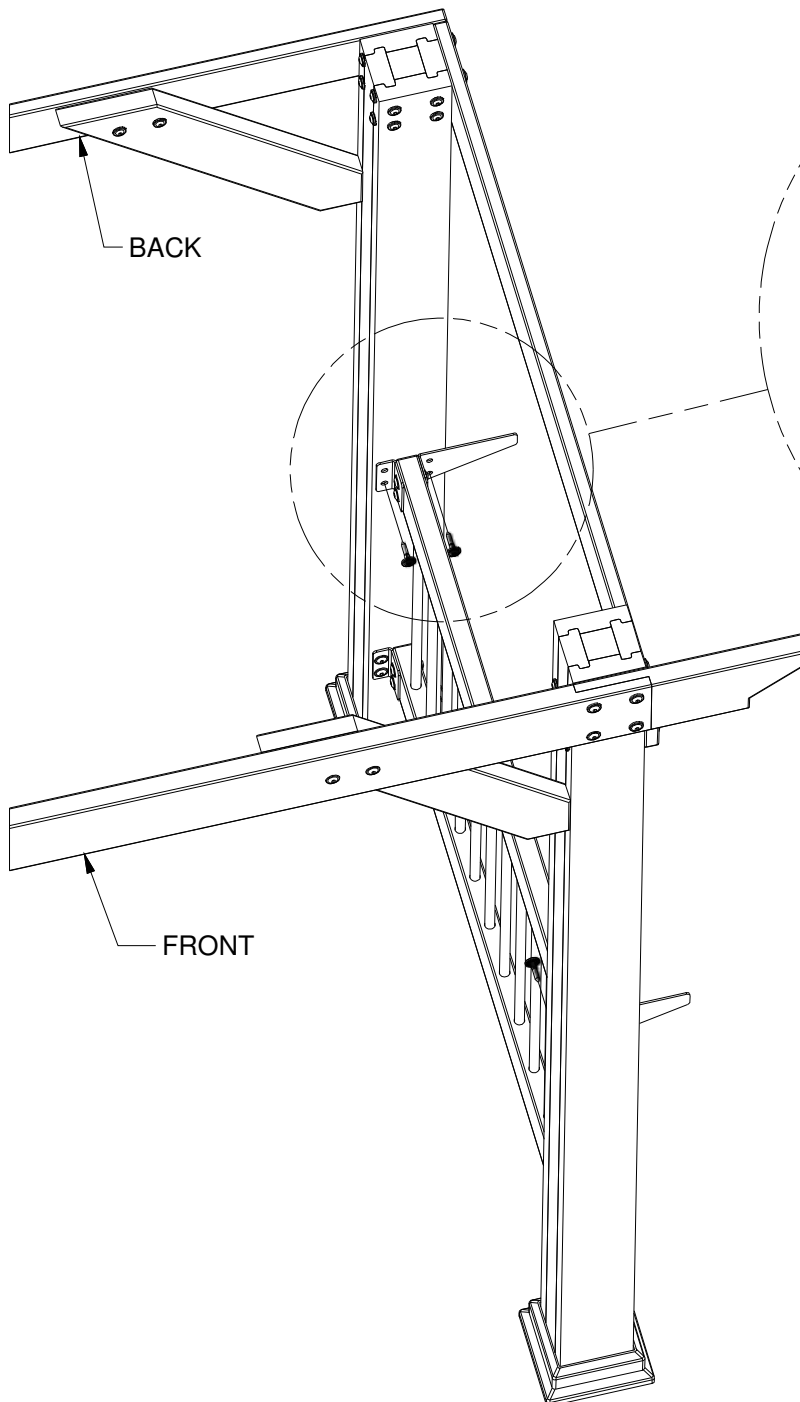

ATTACH BOTTOM TWO SCREWS ONLY, BUT DO NOT TIGHTEN COMPLETELY. TABLE TOP WILL ATTACH TO TOP HOLES IN NEXT STEP. REPEAT ON BOTH ENDS OF RAIL.



STEP 9

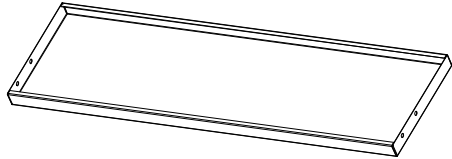

A4M01210 | TABLE
(x2)



H100471 | LAG SCREW WH BLK
(x8) | 5/16x1 1/2

REPEAT STEP FOR OPPOSITE SIDE

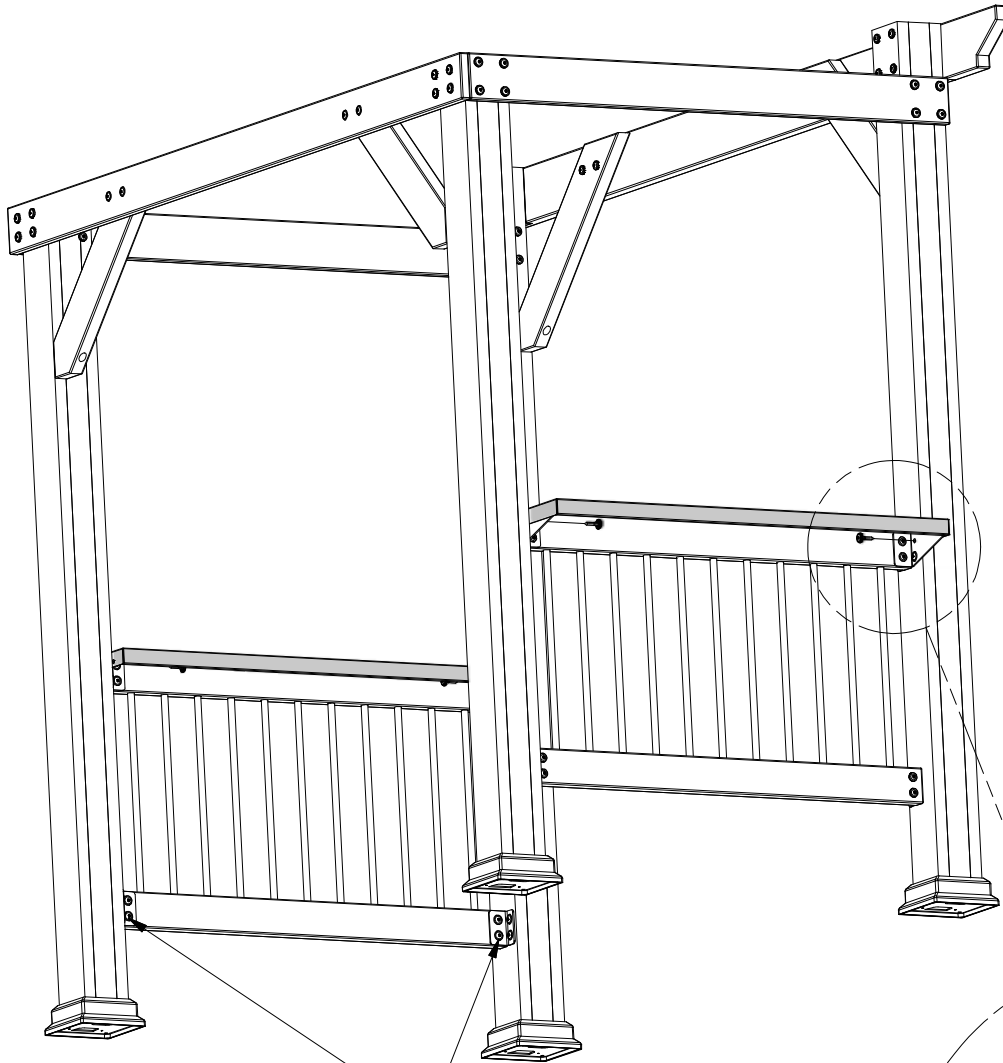

AFTER TABLE IS INSTALLED,
TIGHTEN ALL CONNECTIONS.

471 (x8)
LAG SCREW - 1 1/2"

AFTER TABLE IS ATTACHED,
TIGHTEN THE BOTTOM
SCREWS ON ALL SIDES
AS REQUIRED.

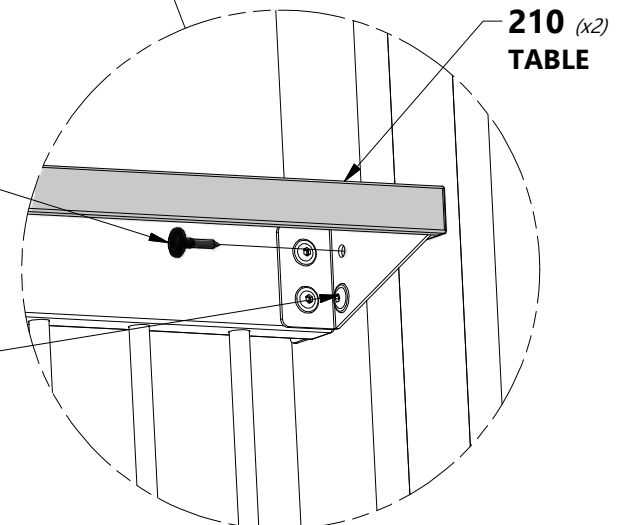



STEP 10

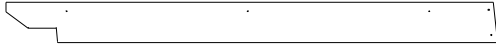

D6 | BEAM - W4L14107
(x1) | 1 3/8"x5 1/4"x64" (36x134x1626)

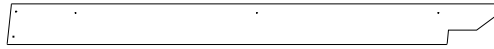

D8 | BEAM - W4L14345
(x1) | 1 3/8"x5 1/4"x64" (36x134x1626)

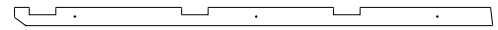

F1 | RAFTER - W4L14108
(x2) | 1 7/16"x2 3/8"x62 5/16" (36x60x1582)



H100201 | SCREW PFH BLK
(x6) | 8x2-1/2

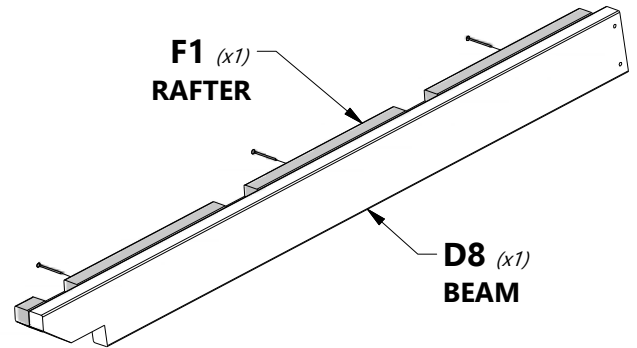
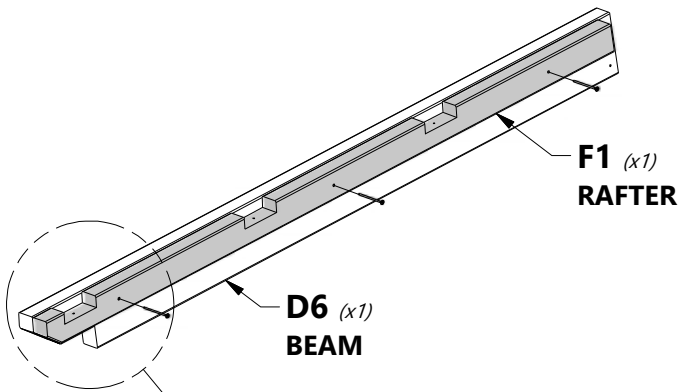

 BEAM & RAFTER TO BE FLUSH

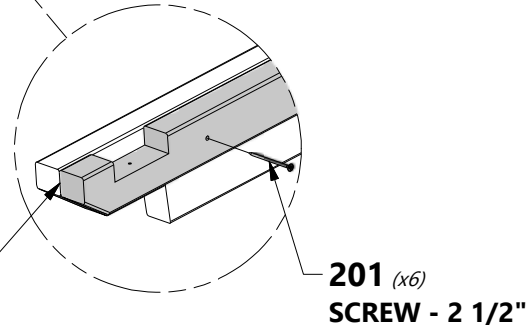



STEP 11

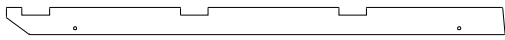

E1 | RAFTER - W4L14111
(x2) | 1 3/8"x3 3/8"x62 3/8" (36x86x1585)



E3 | RAFTER - W4L14971
(x1) | 1 3/8"x3 3/8"x62 3/8" (36x86x1585)

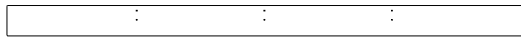

D7 | BEAM - W4L14110
(x1) | 1 3/8"x5 1/4"x89 1/2" (36x134x2272)



H101008 | SCREW CONFIRMAT BLK
(x10) | 7x3

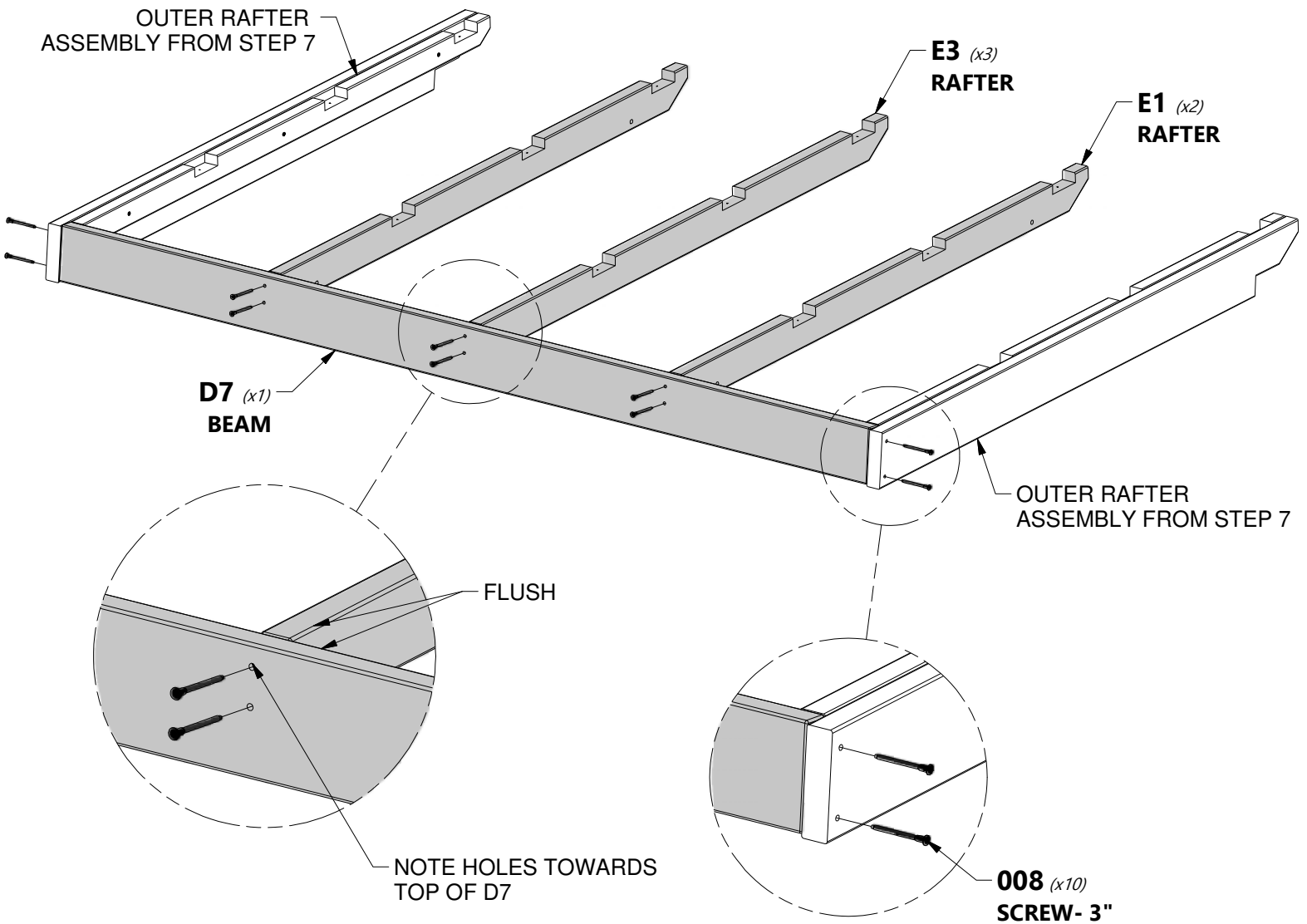



STEP 12

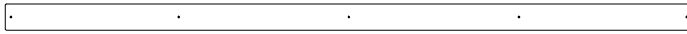

H2 | PURLIN - W4L14109
(x3) | 1"x3 3/8"x89 1/2" (24x86x2272)



H100382 | SCREW PFH BLK
(x15) | 8x1 3/4

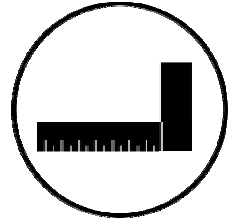

382 (x15)
SCREW - 1 3/4"

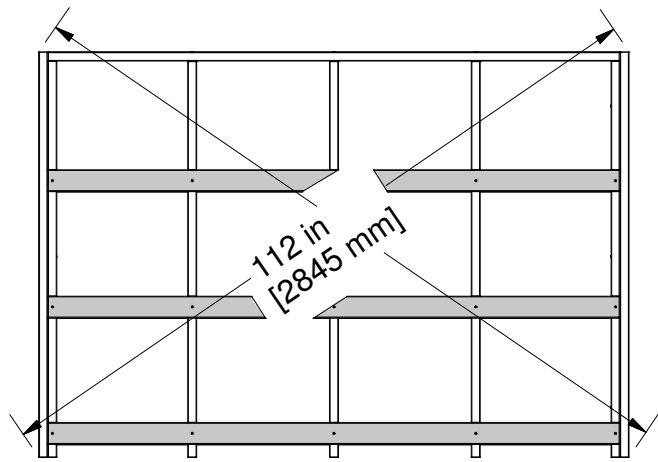
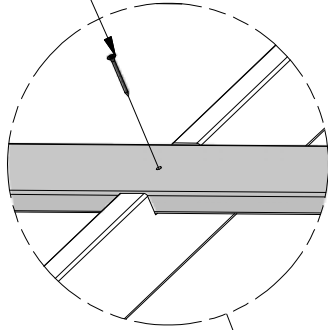

SQUARED ROOF REF DIMENSIONS

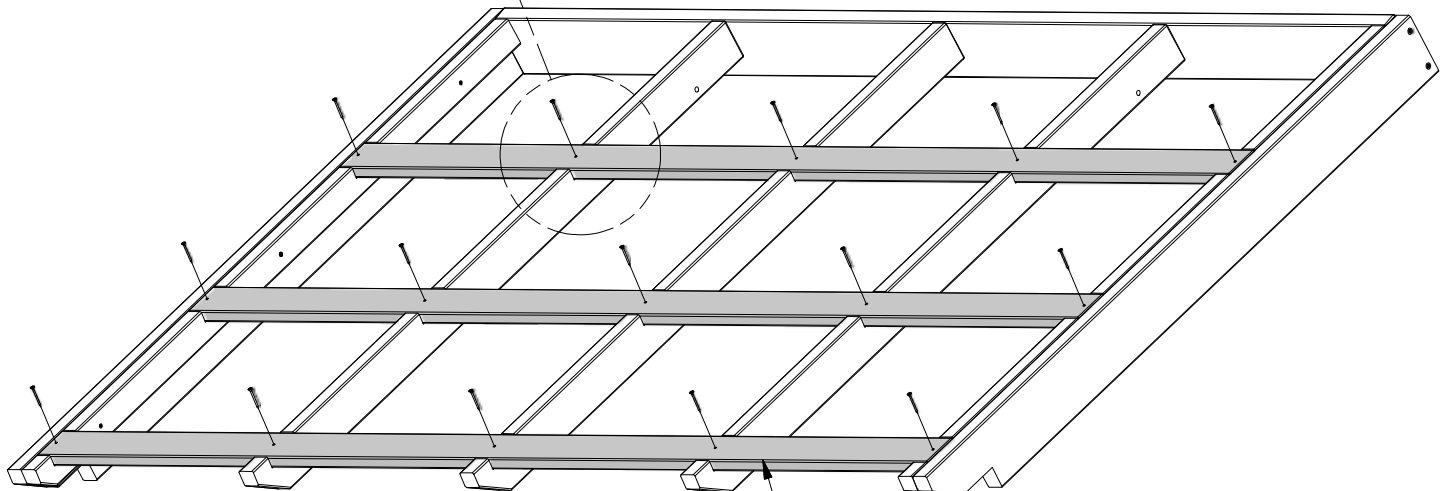

H2 (x3)
PURLIN



STEP 13

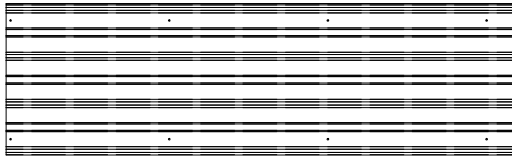

A4M01227
(x5) | **29GA STEEL SHEETING**



H100833 | **SCREW WOODGRIP**
(x40) | **10x3/4**



NOTE:

WARNING:

GLOVES SHOULD BE WORN WHEN HANDLING ROOF PANELS; EDGES ARE SHARP.

LOOKING AT THE FRONT OF THE UNIT AS PICTURED BELOW, PLACE TIN SHEETS DOWN AS SHOWN, STARTING AT THE LEFT SIDE AND WORKING TOWARDS THE RIGHT SIDE.

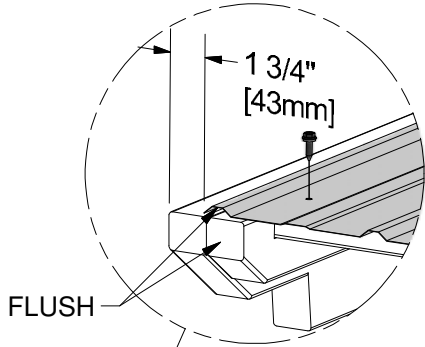

FLUSH

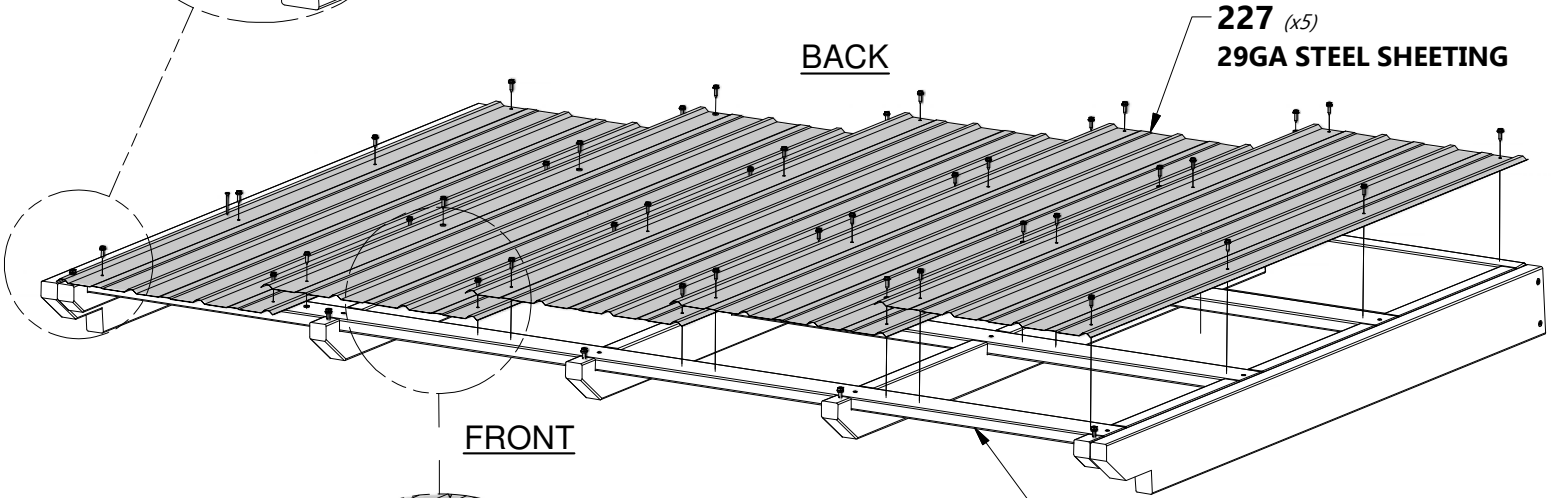

BACK

227 (x5)
29GA STEEL SHEETING

FRONT

ROOF/RAFTER ASSEMBLY FROM PREVIOUS STEPS

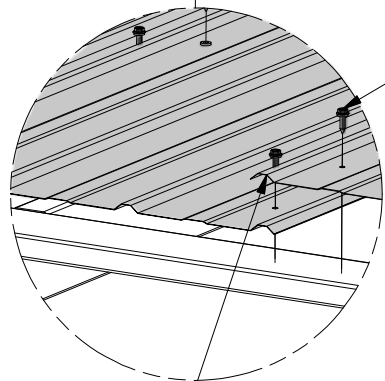

833 (x40)
SCREW - 3/4"

NOTE: SHEETS OVERLAP BY (1) RIB

NOTE HOLE LOCATIONS GO TOWARDS FRONT OF UNIT.

NOTE HOLE LOCATIONS GO TOWARDS REAR OF UNIT.

3 3/8 in
[86 mm]

TOP VIEW
TIN SHEETING

1/2 in
[14 mm]



STEP 14

A4M01160 (x4) | ROOF EDGE TRIM

A4M00983 (x2) | ROOF EDGE TRIM SPLICE

A4M01162 (x2) | ROOF EDGE TRIM

H100759 (x14) | SCREW TAPPING
1/4x3/4



NOTE: SCREWS GO THROUGH EDGE TRIM INTO THE TOP OF THE RIBS IN THE APPROXIMATE LOCATIONS SHOWN. IT IS RECOMMENDED TO PREDRILL EDGE TRIM.



KEEP EDGE SCREWS IN LINE WITH SCREWS ON TIN.

162 (x1) ROOF EDGE TRIM

160 (x2) ROOF EDGE TRIM

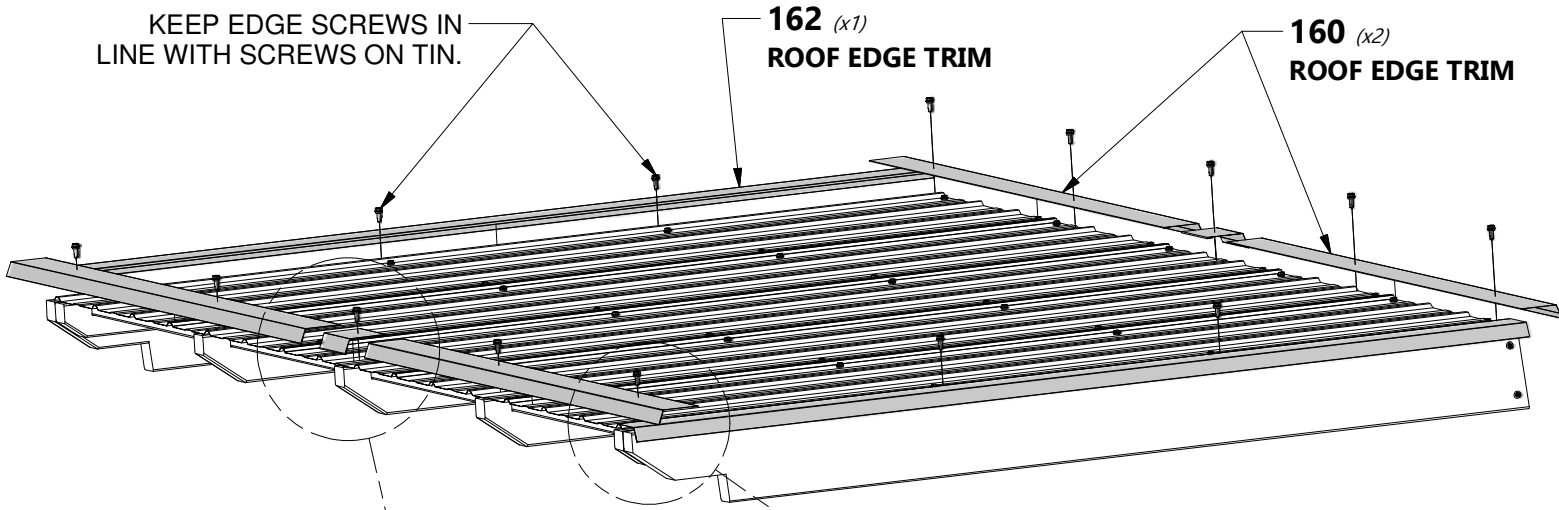

160 (x1) ROOF EDGE TRIM

759 (x14) SCREW - 3/4"

FLUSH

983 (x2) ROOF EDGE TRIM SPLICE

160 (x1) ROOF EDGE TRIM

162 (x1) ROOF EDGE TRIM

SCREWS TO ATTACH TO CENTER OF RAFTERS.



NOTE: SLIDE ROOF EDGE TRIM 160 INTO EACH SIDE OF EDGE TRIM SPLICE 983. PUSH TOGETHER UNTIL ROOF EDGE TRIM 160 IS FLUSH WITH ROOF EDGE TRIM 162 ON EACH SIDE OF THE UNIT. INSTALL SCREWS.

STEP 15

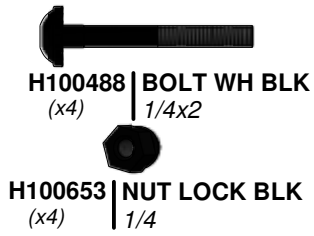
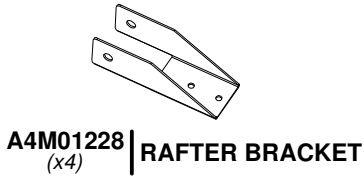

SLIDE ROOF PANEL ON FROM BACKSIDE

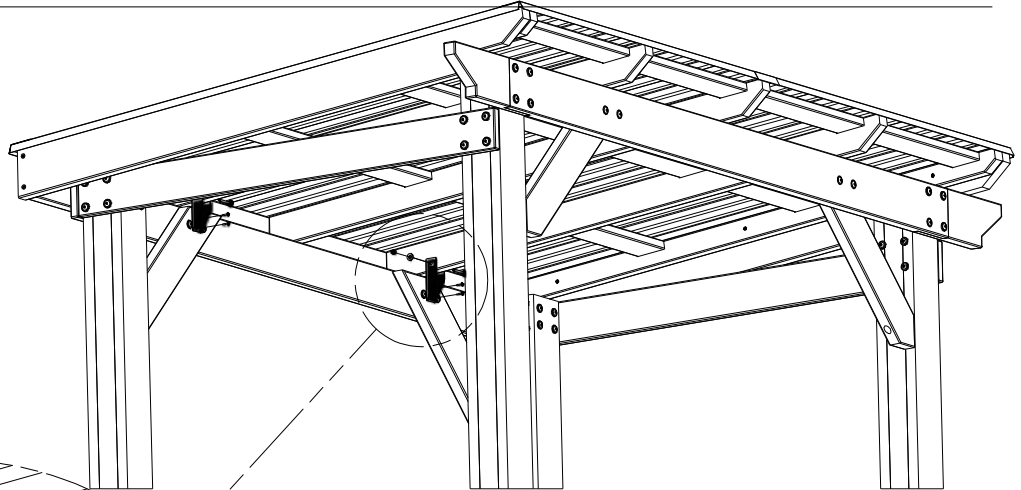

630 (x4)
WASHER - 8x19
653 (x4)
NUT - 1/4"

488 (x4)
BOLT - 2"

392 (x8)
SCREW - 3/4"

CORBELS FROM PREVIOUS STEPS.

228 (x4)
RAFTER BRACKET

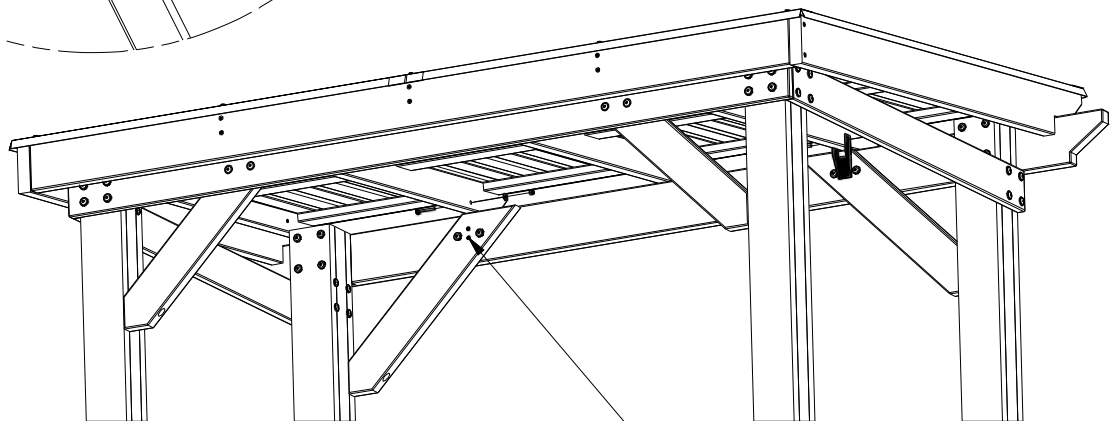

REPEAT STEP TO FASTEN
RAFTER BRACKETS ON
FRONT OF UNIT.



STEP 16



H100630 | WASHER FLAT BLK
(x16) | 8x19



H100120 | SCREW CONCRETE ANCHOR
(x16) | 1/4x2



NOTE:

MANUFACTURER RECOMMENDS INSTALLATION ON CONCRETE SURFACE OR CONCRETE POST PADS. SEE BELOW

FOR INSTALLATION ON WOOD DECK, YOU MUST ENSURE THERE IS AMPLE STRUCTURAL SUPPORT UNDER DECK.

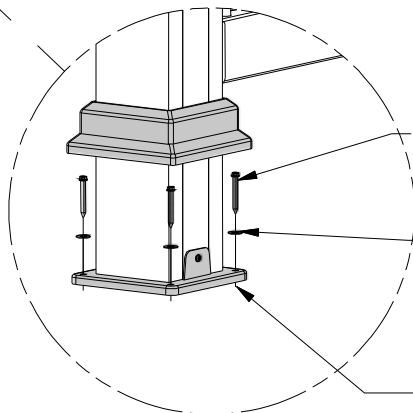
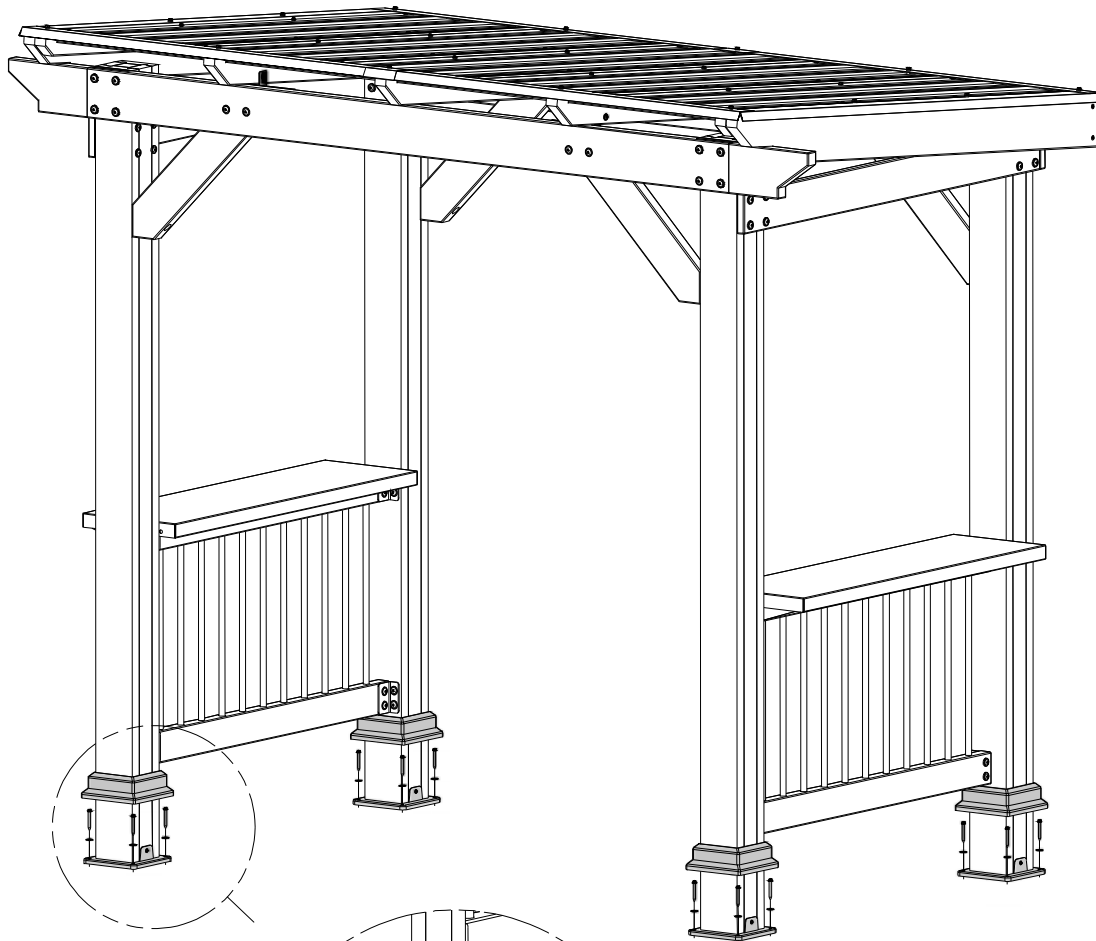

120 (x16)
SCREW - 2"

630 (x16)
WASHER - 8x19



NOTE:

PRE-DRILL HOLES FOR CONCRETE ANCHORS USING A 3/16" CONCRETE DRILL BIT.



STEP 17



A100241 | **BYD ID TAG (SMALL) WITHOUT AGES**
(x1)

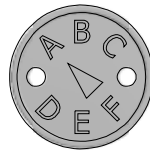

A100314 | **"A" REVISION TAG**
(x1)



H100392 | **SCREW PWH BLK**
(x4) | **8x3/4**

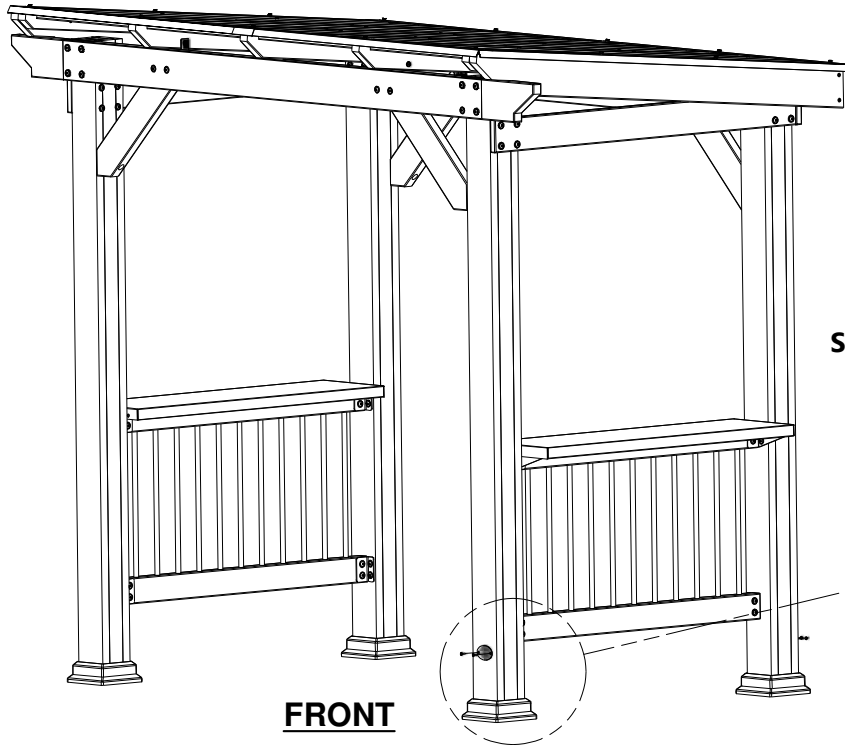

FRONT

392 (x2)
SCREW - 3/4"

241 (x1)

BYD ID TAG (SMALL) WITHOUT AGES

314 (x1)
"A" REVISION TAG

392 (x2)
SCREW - 3/4"

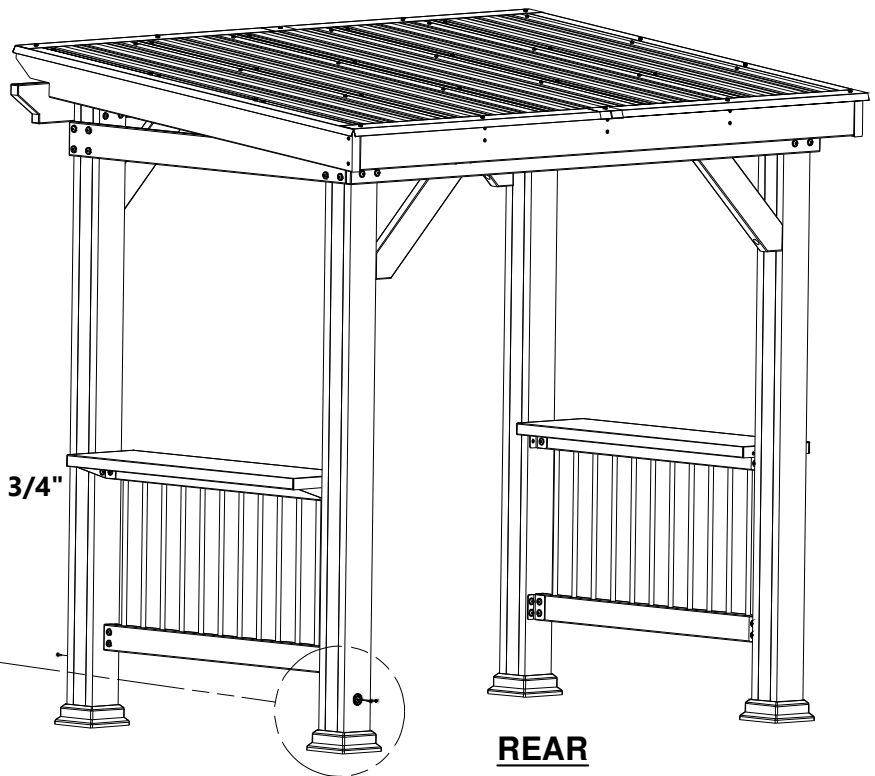
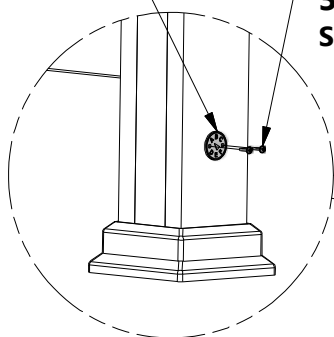

REAR

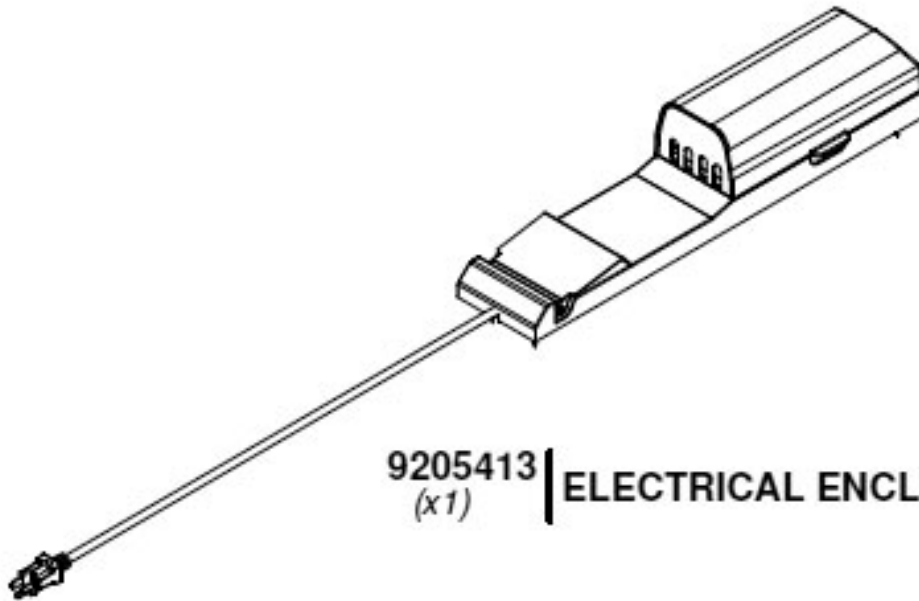

9205413
(x1) | **ELECTRICAL ENCLOSURE**

FOR ELECTRICAL ENCLOSURE INSTALLATION REFER TO ASSEMBLY INSTRUCTIONS THAT COMES PACKAGED WITH THE ELECTRICAL ENCLOSURE KIT. INSTALL ON ANY POST THAT IS DESIRED. FOLLOW DIRECTIONS FOR PROPER INSTALLATION.