



# LOREX<sup>®</sup>

En

## 2K Network Video Recorder (NVR) & Wire-Free Camera System

L4248 Series  
Quick Start Guide

[lorex.com](http://lorex.com)





Thank you for your purchase!

# How to get started with your 2K NVR & Wire-Free Camera system





## Safety precautions

- Read this guide carefully and keep it for future reference.
- Follow all instructions for safe use and handling of the product.
- Operate the camera within the specified temperature, humidity and voltage and use manufacturer approved accessories.
- Do not disassemble the camera.
- Do not point the camera directly at the sun or a source of intense light.
- Periodic cleaning may be required. Use a damp cloth only. Do not use any harsh, chemical-based cleaners.

## Disclaimers

- A regulated UL / CSA approved power supply is required for use with this camera (included). Use of a non-regulated, non-conforming power supply can damage this product and voids the warranty.
- Not intended for submersion in water. Installation in a sheltered location recommended.
- Audio recording without consent is illegal in certain jurisdictions. Lorex Corporation assumes no liability for use of its products that does not conform with local laws.
- This camera includes an Auto Mechanical IR Cut Filter. When the camera changes between Day/Night viewing modes, an audible clicking noise may be heard from the camera. This clicking is normal, and indicates that the camera filter is working.
- Some channels on the 5GHz Wi-Fi band are restricted in Canada. This means certain Wi-Fi networks may not be available to connect to during setup.





# Contents

- Section 1** Package Contents
- 2** NVR Overview
- 3** Camera Overview
- 4** Before You Start
- 5** Camera Setup
- 6** Recorder Setup

- 7** App Setup
- 8** Camera Pairing to the App
- 9** App Live View
- 10** Optional: Setup Wizard
- 11** Install the Camera

# 1 Package Contents



2K NVR  
(x1)

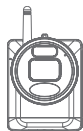

2K Wire-Free  
Security Camera  
(x1)\*



Camera  
Antenna  
(x1)\*



Re-chargeable Camera  
Battery Pack  
(x1)\*



Battery Pack  
Adapter & Cable  
(x1)\*



NVR Power  
Adapter  
(x1)



USB Mouse  
(x1)



Ethernet Cable  
(x1)



HDMI Cable  
(x1)



Allen key (x1)  
Drill bit (x1)  
Screwdriver (x1)



Anchors (x4)\*  
Screws (x4)\*  
Security Screws (x2)\*

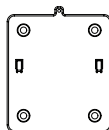

Mounting  
Bracket  
(x1)\*

\*Dependent on the number of cameras included.



## 2 NVR Overview

FRONT

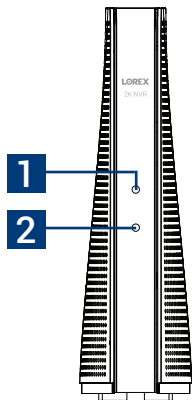

1. Power status indicator
2. HDD status indicator

BACK

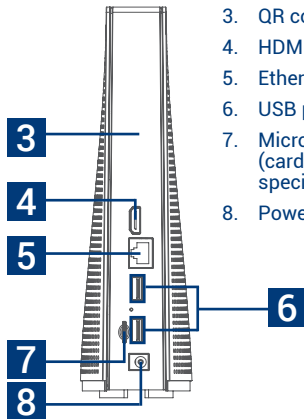

3. QR code
4. HDMI port
5. Ethernet port
6. USB port (x2)
7. MicroSD slot (card included for specific models)
8. Power port

### Status indicator

Power status indicator	● (solid)	Operating correctly
HDD status indicator	● (solid)	Hard disk drive installed

### Dimensions

- Height: 8.6" (220mm)
- Width: 2.5" (64mm)
- Length: 6.7" (169mm)





### 3 Camera Overview

FRONT

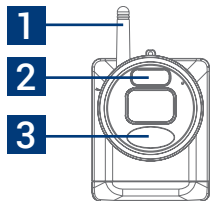

1. Detachable antenna
2. Warning light
3. PIR sensor
4. Locking screw
5. Power port
6. Battery charging indicator

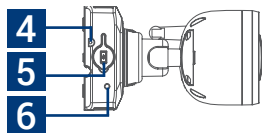

BOTTOM

SIDE

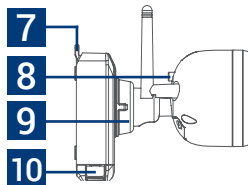

7. Fastener
8. Pairing button
9. Adjustment ring
10. Battery release tabs (x2)
11. Mounting plate slots (x2)

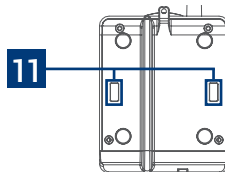

BACK MOUNTING PLATE

### Dimensions

- Height: 4.8" (121mm)
- Width: 5.2" (131mm)
- Length: 2.9" (73mm)





## 4 Before You Start

The camera battery comes partially charged (due to safety regulations). Please, fully charge the battery before use and setup. You can charge the battery pack inside or outside of the camera.

### To charge the camera battery pack:

1. Remove the protective film on the battery contacts and camera lens.
2. Using the provided battery charging adapter and cable, connect the camera to a nearby outlet.

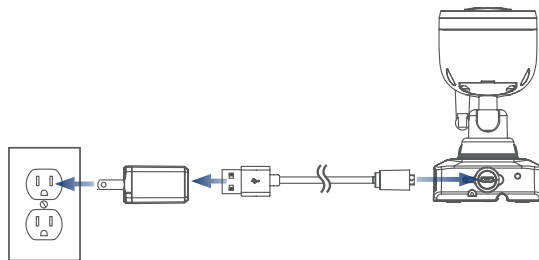

### Camera battery charging indicator

 (solid)	Fully charged
 (solid)	Charging

### Battery charging time

2-cell	Approx. 6 hours
3-cell	Approx. 8 hours







## 5 Camera Setup

1. Turn the adjustment ring counter-clockwise to loosen and reposition the camera.
2. Screw in the antenna.
3. Insert the power pack into the bottom of the camera.

**Note:** You will hear a 'beep' when the power pack is properly inserted. If you do not hear this alert, remove the power pack by pushing in on the battery release tabs then re-insert.

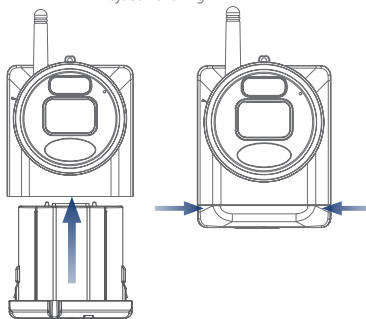
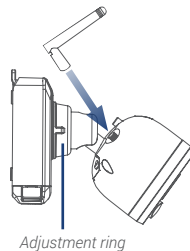



## 6 Recorder Setup

1. Connect the included NVR power adapter to the recorder.
2. Connect the recorder to your router using the included Ethernet cable.

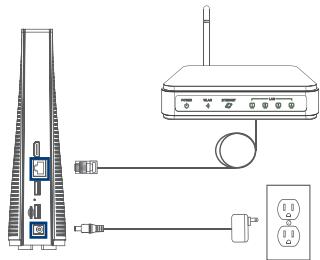

### Optional: Full Recorder Setup

1. Connect a monitor using the included HDMI cable.
2. Connect the included USB mouse to one of the USB ports.

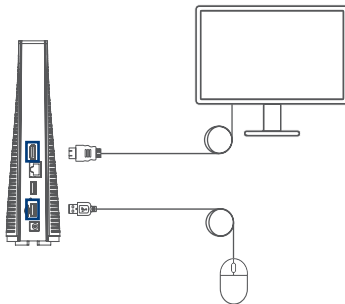

## 7 App Setup

1. Download the **Lorex Cirrus app** by scanning the QR code.
2. Open the Lorex Cirrus app.
3. Tap  to open the menu, then tap **Device List**.
4. Tap the **+** icon. Follow the in-app instructions.
5. Enter the following information, then tap **Save**.
  - **Media Port:** 35000
  - **Password:** 00000000
6. A pop-up will display prompting you to change your password, tap **OK**.
7. Follow the in-app instructions to complete the setup.

A screenshot of the 'Edit Information' screen in the Lorex Cirrus app. The screen has a dark blue header with a back arrow and the text 'Edit Information'. Below the header are four input fields: 'IP Address/ID' with the value 'LWFPJ933AY2U', 'Media Port' with the value '35000', 'User Name' with the value 'admin', and 'Password' with a masked password of ten dots. A 'Save' button is located at the bottom of the screen.

## 8 Camera Pairing to the App

1. From the Home screen, select your recorder from the list of devices.
2. Tap any free channel marked with a  icon.
3. Tap **Pair**.
4. Press and hold the pairing button on the back of the camera until the red LED lights stop flashing, then release the pairing button. A **'Pairing success!'** message will appear on screen. If you do not see this message, repeat steps 1-4.

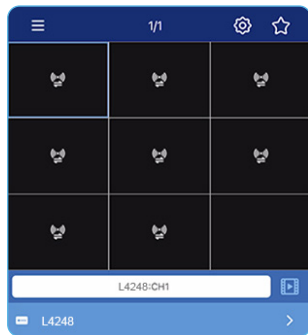

### Optional: Pairing on the recorder

Click the  icon in an empty channel screen.

After you press and hold the pairing button on the back of your camera, you will have 30 seconds to pair the camera.

## 9 App Live View

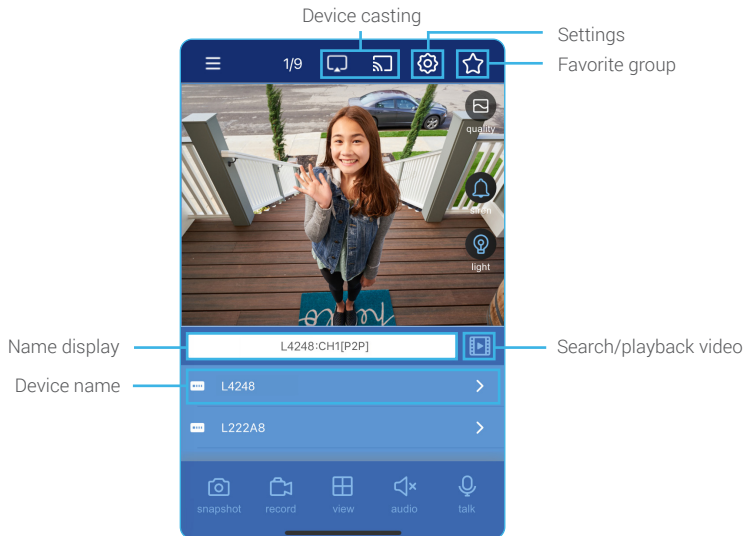



## 10 Optional: Setup Wizard

When using the recorder's interface, you will have to complete the Recorder Setup Wizard. The Wizard will help you to configure core system settings and appears once you connect a monitor.

Log in using the system user name (default: **admin**) and the new password you created when setting up the recorder, then complete the on-screen instructions.

For a complete overview of NVR controls available with the Full Recorder Setup, go to [lorex.com/2K-NVR-WFCamera](http://lorex.com/2K-NVR-WFCamera).

### Using the mouse



- **During split-screen display:** Click an individual channel to view in full-screen. Click again to return to the split-screen display mode.
- **While navigating menus:** Click to open a menu option.
- **During live view:** Click anywhere on the screen to open the Quick Menu.
- **While navigating menus:** Click to exit menus.
- **During live view:** Scroll to move up/down through the menu content. Hover the mouse cursor over/away from the top of the screen to open/close the Navigation bar.





## 11 Install the camera

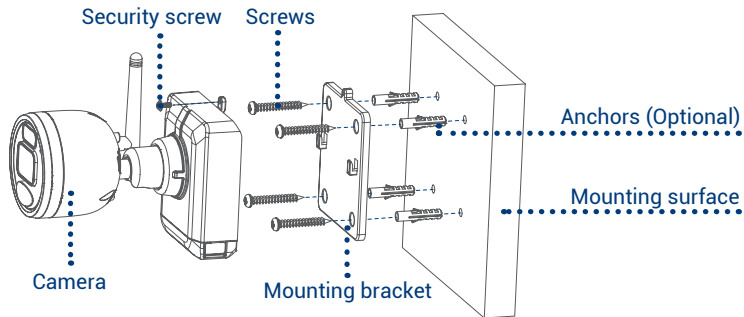

1. Set the mounting bracket in the desired mounting position.
2. Mark holes through the mounting bracket.
3. Using the included drill bit, drill holes where marked.
4. Using the included screwdriver, secure the bracket with the provided mounting screws.  
**Optional:** If you are mounting the camera into drywall, use the provided drywall anchors.





5. Align the camera's mounting plate slots to the tabs in the mounting bracket. Push in and slide down to secure in place.
6. Insert the security screw through the fasteners on the top of the camera and mounting bracket, then tighten with the screwdriver.
7. Tighten the pre-installed locking screw using the screwdriver.

**Note:** To remove the power pack in the future, loosen the locking screw.

8. Adjust the camera to the desired position. Tighten the adjustment ring clockwise.

*Pre-installed locking screw*

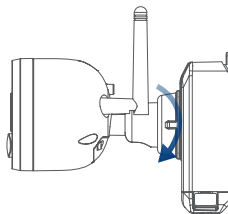
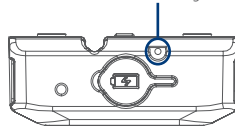





## Need help?

Visit [help.lorex.com](https://help.lorex.com) for up-to-date information and resources:

- Download product guides
- Watch how-to-videos
- Find related troubleshooting tips & FAQs

## Register your product

Please see our full Terms of Service and Limited Hardware Warranty Policy visit, [lorex.com/warranty](https://lorex.com/warranty).



This device complies with part 15 of the FCC Rules. Operation is subject to the following two conditions: (1) This device may not cause harmful interference, and (2) This device must accept any interference received, including interference that may cause undesired operation.

Copyright © 2021 Lorex Corporation

As our products are subject to continuous improvement, Lorex reserves the right to modify product design, specifications and prices, without notice and without incurring any obligation. E&OE. All rights reserved.

*L4248-Series\_QSG\_TRILINGUAL\_R1*





# LOREX<sup>®</sup>

Fr

## Enregistreur vidéo en réseau 2K (NVR) et le système de caméra sans fils 2K

Série L4248

Guide de démarrage rapide

[lorex.com](http://lorex.com)





Merci pour votre achat!

Voici comment démarrer votre NVR 2K  
et votre système de caméra sans fil





## Mesures de sécurité

- Lisez attentivement ce guide et gardez-le pour consultation ultérieure.
- Veuillez suivre les directives pour assurer une utilisation et une manipulation sécuritaires du produit.
- Faites fonctionner la caméra dans les limites de température, d'humidité et de tension spécifiées et utilisez les accessoires approuvés par le fabricant.
- Ne démontez pas la caméra.
- Ne pointez pas votre caméra vers le soleil ou une source intense de lumière.
- Un nettoyage périodique peut s'avérer nécessaire. Utilisez uniquement un linge humide. N'utilisez pas de nettoyeurs à base de produits chimiques abrasifs.

## Clauses de non-responsabilité

- Un bloc d'alimentation stabilisé et certifié UL/CSA est nécessaire pour l'utilisation de cette caméra (fourni). L'utilisation d'un bloc d'alimentation non réglementé et non conforme peut endommager ce produit et annuler la garantie.
- Ne pas immerger dans l'eau. Installation recommandée dans un emplacement abrité.
- L'enregistrement audio sans consentement est illégal sur certains territoires. Lorex Corporation décline toute responsabilité concernant l'usage de produits non conformes aux lois locales.
- Cet appareil comprend un filtre IR mécanique autonome. Lorsque la caméra passe du mode diurne au mode nocturne, un bruit de clic provenant de la caméra peut être entendu. Ce clic est normal et indique que le filtre de la caméra fonctionne.
- Certains canaux de la bande Wi-Fi de 5 GHz sont interdits au Canada. Cela signifie que certains réseaux Wi-Fi peuvent ne pas être disponibles pour la connexion pendant l'installation.





# Contenu

- Section 1** Contenu de l'emballage
- 2** Vue d'ensemble du NVR
- 3** Vue d'ensemble de la caméra
- 4** Avant de commencer
- 5** Configuration de la caméra
- 6** Configuration de l'enregistreur
- 7** Configuration de l'application
- 8** Jumelage de la caméra avec l'application
- 9** Visionnement de l'application en direct
- 10** Optionnel : Assistant de configuration
- 11** Installation de la caméra



# 1 Contenu de l'emballage



NVR 2K  
(x1)



Caméra de sécurité  
2K sans fil (x1)\*



Antenne de  
caméra  
(x1)\*

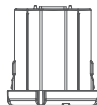

Bloc-piles rechargeable  
pour la caméra (x1)\*



Adaptateur de  
bloc-piles et câble  
(x1)\*



Adaptateur  
d'alimentation de  
NVR (x1)



Souris USB  
(x1)



Câble Ethernet  
(x1)

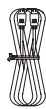

Câble HDMI  
(x1)



Clé Allen (x1)  
Mèche de forage (x1)  
Tournevis (x1)



Ancrages (x4)\*  
Vis (x4)\*  
Vis de sécurité (x2)\*

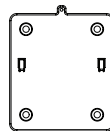

Support de  
montage (x1)\*

\* Cela dépend du nombre de caméras incluses.



## 2 Vue d'ensemble du NVR

AVANT

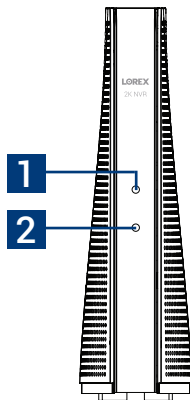

1. Indicateur d'état d'alimentation
2. Indicateur d'état HDD

PRÉCÉDENT

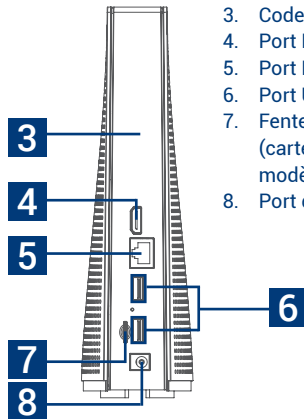

3. Code QR
4. Port HDMI
5. Port Ethernet
6. Port USB (x2)
7. Fente de carte micro SD (carte incluse pour des modèles spécifiques)
8. Port d'alimentation

### Indicateur d'état

Indicateur d'état d'alimentation	<span style="color: blue;">●</span> (permanent)	Bon fonctionnement
Indicateur d'état HDD	<span style="color: red;">●</span> (permanent)	Disque dur installé

### Dimensions

- Hauteur : 220 mm (8,6 po)
- Largeur : 64 mm (2,5 po)
- Longueur : 169 mm (6,7 po)



### 3 Vue d'ensemble de la caméra

AVANT

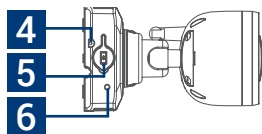
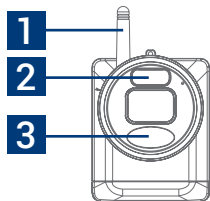

PARTIE INFÉRIEURE

1. Antenne démontable
2. Voyant d'avertissement
3. Capteur passif à infrarouge
4. Vis de blocage
5. Port d'alimentation
6. Indicateur de charge de la pile

CÔTÉ

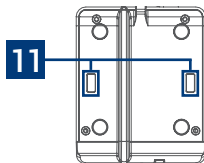
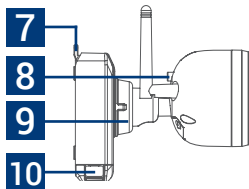

PLAQUE DE MONTAGE  
ARRIÈRE

7. Fixation
8. Bouton de jumelage
9. Bague de réglage
10. Languettes d'ouverture du bloc-pile (x2)
11. Fentes de la plaque de montage (x2)

### Dimensions

- Hauteur : 121 mm (4,8 po)
- Largeur : 131 mm (5,2 po)
- Longueur : 73 mm (2,9 po)



## 4 Avant de commencer



Les piles de la caméra sont livrées partiellement chargées (en raison des règles de sécurité). Prenez soin de charger complètement les piles avant l'utilisation et l'installation. Vous pouvez charger le bloc-piles à l'intérieur ou à l'extérieur de la caméra.

### Pour charger le bloc-piles de la caméra :

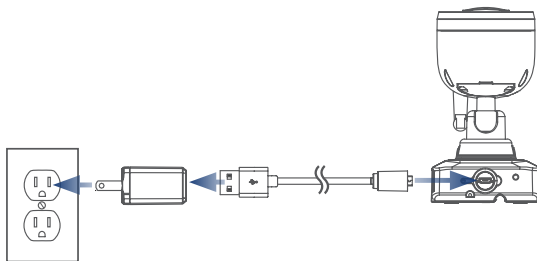
1. Retirez le film protecteur des contacts des piles et de la lentille de la caméra.
2. En utilisant l'adaptateur de bloc-pile et le câble fournis, branchez le caméra à la prise de courant la plus proche.



### Indicateur de charge de la pile de la caméra

 (permanent)	Complètement chargé
 (permanent)	Chargement

### Temps de recharge des piles

Deux cellules	Environ six heures
Trois cellules	Environ huit heures



## 5 Configuration de la caméra

1. Tournez la bague de réglage dans le sens des aiguilles d'une montre pour relâcher et repositionner la caméra.
2. Visser l'antenne.
3. Insérez le bloc d'alimentation dans la base de la caméra.

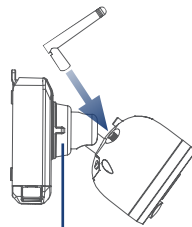

*Bague de réglage*

**Remarque :** Vous entendrez un « **signal sonore** » lorsque le bloc d'alimentation est correctement inséré. Si vous n'entendez pas cette alerte, retirez le bloc-pile en appuyant sur les languettes d'ouverture, puis réinsérez-le.

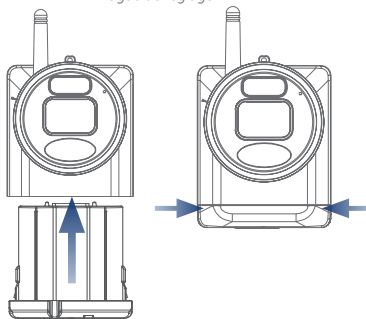



## 6 Configuration de l'enregistreur

1. Connectez l'adaptateur d'alimentation inclus à NVR.
2. Connectez l'enregistreur à votre routeur à l'aide du câble Ethernet inclus.

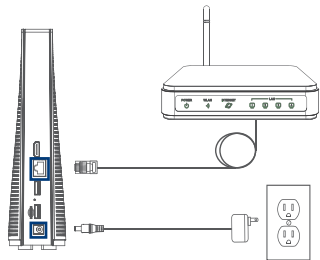

### Optionnel: Installation complète de l'enregistreur

1. Connectez un moniteur à l'aide du câble HDMI fourni.
2. Connectez la souris USB incluse à l'un des ports USB.

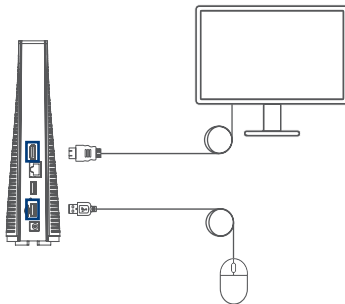

## 7 Configuration de l'application

1. Téléchargez l'**application Lorex Cirrus** en balayant le code QR.
2. Ouvrez l'application Lorex Cirrus.
3. Appuyez sur  pour ouvrir le menu, puis appuyez sur **Device List**.
4. Appuyez sur l'icône **+**. Suivez les instructions dans l'application.
5. Configurez les éléments suivants, puis appuyez sur **Save**.
  - **Media Port** : 35000
  - **Password** : 00000000
6. Une fenêtre contextuelle s'affichera pour vous inviter à changer votre mot de passe, appuyez sur **OK**.
7. Suivez les instructions dans l'application pour terminer l'installation.

A screenshot of the 'Edit Information' screen in the Lorex Cirrus application. The screen has a dark blue header with a back arrow on the left and the title 'Edit Information'. Below the header are four input fields: 'IP Address/ID' with the value 'LWFPJ933AY2U', 'Media Port' with the value '35000', 'User Name' with the value 'admin', and 'Password' with a masked value of ten black dots. A 'Save' button is located at the bottom of the screen.

## 8 Jumelage de la caméra avec l'application

1. À partir de l'écran d'accueil, sélectionnez votre enregistreur dans la liste d'appareils.
2. Appuyez sur n'importe quel canal libre marqué avec une icône .
3. Appuyez sur **Pair**.
4. Appuyez et maintenez le bouton de jumelage à l'arrière de la caméra jusqu'à ce que les feux LED rouges cessent de clignoter, puis relâchez le bouton de jumelage. Le message « **Pairing success!** » apparaîtra à l'écran. Si vous ne voyez pas ce message, répétez étapes 1-4.

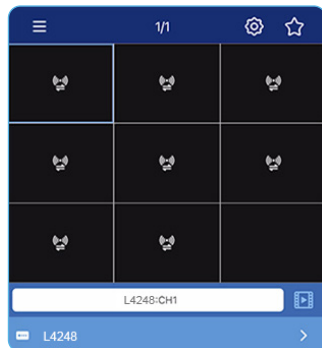

### Optionnel : Jumelage sur l'enregistreur

Cliquez sur l'icône  dans l'écran d'un canal vide. Après avoir appuyé le bouton de jumelage qui se situe à l'arrière de votre caméra et en le maintenant appuyé, vous aurez 30 secondes pour jumeler la caméra.

## 9 Visionnement de l'application en direct

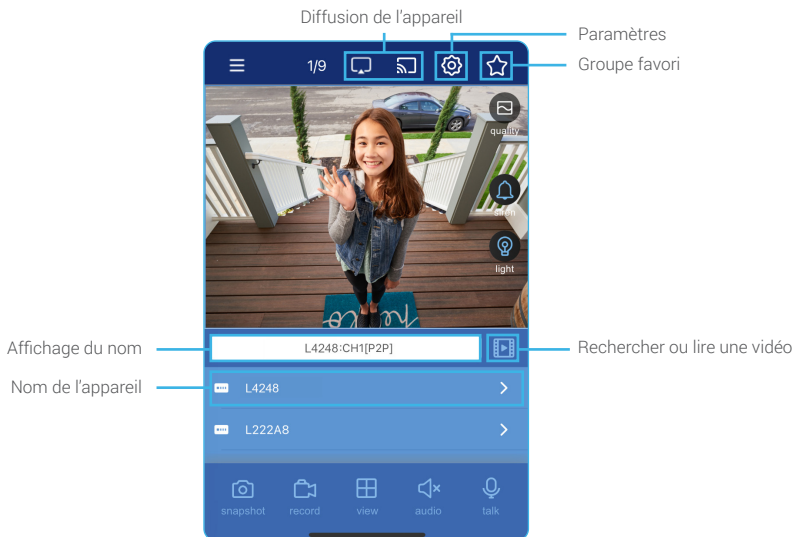



## 10 Optionnel : Assistant de configuration

Lors de l'utilisation de l'interface de l'enregistreur, vous devez compléter l'assistant de configuration de l'enregistreur. L'assistant vous aidera à configurer les paramètres de base du système et il apparaît une fois que vous connectez un moniteur.

Connectez-vous en utilisant le nom d'utilisateur du système (par défaut : **admin**) et le nouveau mot de passe que vous avez créé lors de la configuration de l'enregistreur, puis suivez les instructions qui figurent à l'écran.

Pour une vue d'ensemble complète des contrôles NVR disponibles avec la configuration complète de l'enregistreur, accédez à [lorex.com/2K-NVR-WFCCamera](http://lorex.com/2K-NVR-WFCCamera).

### Utilisation de la souris



- **En mode écran partagé** : Cliquez sur un canal individuel pour visionner en mode plein écran. Cliquez dessus à nouveau pour retourner au mode d'affichage d'écran partagé.
- **Lors de la navigation entre les menus** : Cliquez pour ouvrir une option de menu
- **Lors du visionnement en direct** : Cliquez n'importe où sur l'écran pour ouvrir le menu rapide.
- **Lors de la navigation entre les menus** : Cliquez pour sortir des menus.
- **Lors du visionnement en direct** : Utiliser la roulette de défilement pour faire défiler les éléments du menu.  
Passez le curseur de la souris en l'approchant ou l'éloignant du dessus de l'écran pour ouvrir ou fermer la barre de navigation.



## 11 Installation de la caméra

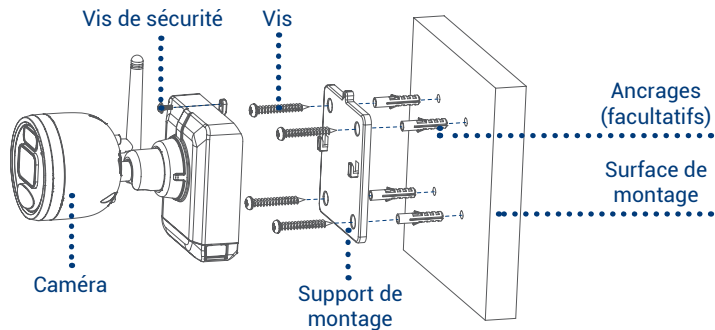

1. Placez le support de montage dans la position souhaitée.
2. Marquez les trous à travers le support de montage.
3. À l'aide de la mèche de forage fournie, percez les trous marqués.
4. Utilisez le tournevis fourni pour fixer le support de montage avec les vis de montage fournies.  
**Optionnel** : Si vous montez la caméra sur le placoplatre, utilisez les ancrages fournis.





5. Alignez les fentes de la plaque de montage de la caméra sur les languettes du support de montage. Poussez et faites glisser vers le bas pour le fixer en place.
6. Insérez la vis de sécurité dans les fixations sur la base de la caméra et le support de montage, Puis, serrez avec le tournevis.
7. Resserrer la vis de verrouillage en utilisant un tournevis.

**Remarque :** Pour le retrait ultérieur du bloc d'alimentation, relâchez la vis de blocage.

8. Réglez la caméra à la position désirée. Serrez l'anneau d'ajustement dans le sens des aiguilles d'une montre.

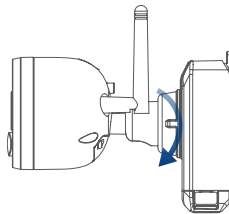
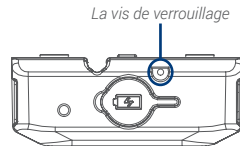



## Besoin d'aide?

Consultez la page [help.lorex.com](https://help.lorex.com) pour obtenir des informations et des ressources à jour :

- Téléchargez les guides de produits
- Regardez des vidéos pratiques
- Trouvez des conseils en matière de dépannage et des FAQ connexes

## Enregistrez votre produit

Veillez consulter nos conditions d'utilisation complètes et notre politique de garantie limitée du matériel sur le site [lorex.com/warranty](https://lorex.com/warranty).



Cet appareil est conforme à la partie 15 des règlements de la FCC. Son fonctionnement est soumis aux deux conditions suivantes : (1) Cet appareil ne doit pas provoquer d'interférences nuisibles, et (2) Cet appareil doit accepter toute interférence reçue, incluant toute interférence pouvant causer un fonctionnement indésirable.

Copyright © 2021 Lorex Corporation

Nos produits étant sans cesse améliorés, Lorex se réserve le droit de modifier la conception du produit, ses caractéristiques et son prix sans préavis et sans aucune obligation. E&OE. Tous droits réservés.

*L4248-Series\_QSG\_TRILINGUAL\_R1*





# LOREX<sup>®</sup>

Es

## Grabadora de vídeo en red 2K (NVR) y sistema de cámara sin cables

Serie L4248

Guía de inicio rápido

[lorex.com](http://lorex.com)





¡Gracias por su compra!

# Cómo empezar con su 2K NVR y Sistema de cámara sin cables





## Precauciones de seguridad

- Lea esta guía atentamente y guárdela para referencias futuras.
- Siga todas las instrucciones para usar y manejar el producto de manera segura.
- Opere la cámara dentro de la temperatura, humedad y voltaje especificados y use accesorios aprobados por el fabricante.
- No desarme la cámara.
- No apunte la cámara directamente al sol o a fuentes de luz intensa.
- Es posible que se requiera una limpieza periódica. Utilice solamente un paño humedecido. No utilice limpiadores abrasivos o de base química.

## Descargo de responsabilidad

- Se requiere una fuente de alimentación aprobada y regulada por UL/CSA para el uso de esta cámara (incluida).  
El uso de una fuente de alimentación que no esté en conformidad con las normas y no esté regulada puede dañar este producto y anula la garantía.
- No está diseñado para sumergirse en el agua. Se recomienda la instalación en una ubicación resguardada.
- La grabación de audio sin consentimiento previo es ilegal en ciertas jurisdicciones. Lorex Corporation no asume responsabilidad alguna por el uso de sus productos de modos que no cumplan con las leyes locales.
- Esta cámara incluye un filtro de corte de IR mecánico automático. Cuando la cámara pasa del modo de visualización diurno al modo nocturno y viceversa, puede oírse un clic que proviene de la cámara. Este sonido es normal e indica que el filtro de la cámara está funcionando.
- Algunos canales de la banda wifi de 5 GHz están restringidos en Canadá. Esto significa que es posible que ciertas redes wifi no estén disponibles para conectarse durante la configuración.





# Contenido

- Sección 1** Contenido del paquete
- 2** Descripción general de la NVR
- 3** Descripción general de la cámara
- 4** Antes de comenzar
- 5** Configuración de la cámara
- 6** Configuración de la grabadora
- 7** Configuración de la aplicación
- 8** Emparejamiento de la cámara con la aplicación
- 9** Visualización en vivo en la aplicación
- 10** Opcional: Asistente de configuración
- 11** Instalación de la cámara



# 1 Contenido del paquete



NVR 2K  
(x1)

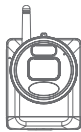

Cámara de seguridad  
inalámbrica 2K  
(x1)\*



Antena de  
cámara  
(x1)\*



Paquete de baterías  
recargables de la  
cámara (x1)\*



Cable y adaptador  
del paquete de  
baterías (x1)\*



Adaptador de  
corriente NVR  
(x1)



Mouse USB  
(x1)



Cable Ethernet  
(x1)

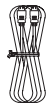

Cable HDMI  
(x1)



Llave Allen (x1)  
Broca (x1)  
Destornillador (x1)



Anclajes (x4)\*  
Tornillos (x4)\*  
Tornillos de seguridad  
(x2)\*

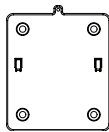

Soporte de  
montaje (x1)\*

\*Depende del número de cámaras incluidas.



## 2 Descripción general de la NVR

PARTE FRONTAL

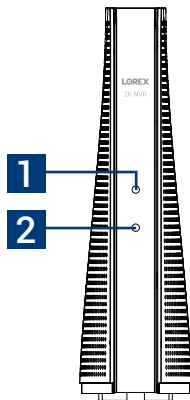

1. Indicador del estado de energía
2. Indicador de estado del HDD

ATRÁS

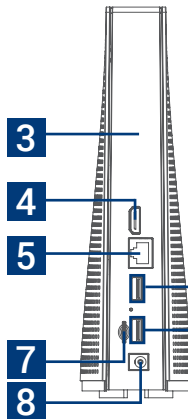

3. Código QR
4. Puerto HDMI
5. Puerto Ethernet
6. Puerto USB (x2)
7. Ranura microSD (Tarjeta incluida para modelos específicos)
8. Puerto de alimentación

### Indicador de estado

Indicador del estado de energía	<span style="color: blue;">●</span> (encendido fijo)	Funcionando correctamente
Indicador de estado del HDD	<span style="color: red;">●</span> (encendido fijo)	Unidad del disco duro instalada

### Dimensiones

- Altura: 8.6 in (220 mm)
- Ancho: 2.5 in (64 mm)
- Largo: 6.7 in (169 mm)







### 3 Descripción general de la cámara

PARTE FRONTAL

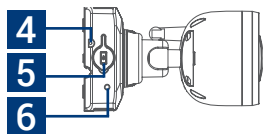
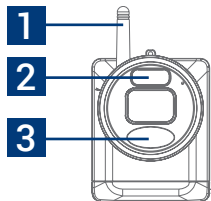

INFERIOR

1. Antena desmontable
2. Luz de advertencia
3. Sensor infrarrojo pasivo (PIR)
4. Tornillo de seguridad
5. Puerto de alimentación
6. Indicador de carga de la batería

LATERAL

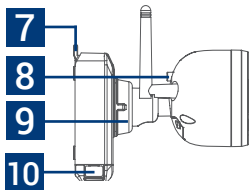

7. Sujetador
8. Botón de emparejamiento
9. Anillo de ajuste
10. Pestañas de liberación (x2)
11. Ranuras de la placa de montaje (x2)

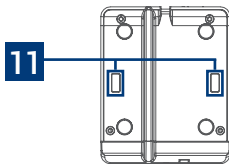

PLACA DE MONTAJE  
MAGNÉTICA

#### Dimensiones

- Altura:  
4.8 in (121 mm)
- Ancho:  
5.2 in (131 mm)
- Largo:  
2.9 in (73 mm)



## 4 Antes de comenzar

Las baterías de la cámara vienen parcialmente cargadas (debido a las normas de seguridad). Cargue completamente la batería antes de usarla y configurarla. Puede cargar el paquete de baterías dentro y fuera de la cámara.

### Para cargar el paquete de baterías de la cámara:

1. Retire la película protectora de los contactos de la batería y el lente de la cámara.
2. Utilizando el adaptador de carga de la batería y el cable suministrados, conecte la cámara a una toma de corriente cercana.

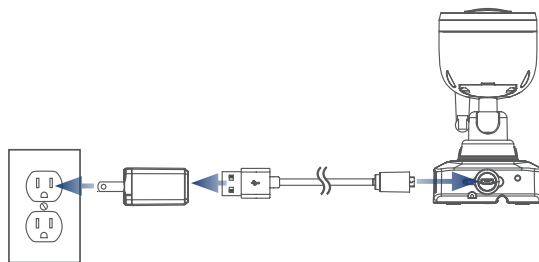

### Indicador de carga de la batería de la cámara

	(encendido fijo)	Carga total
	(encendido fijo)	Cargando

### Tiempo de carga de la batería

2 células	Aprox. 6 horas
3 células	Aprox. 8 horas



## 5 Configuración de la cámara

1. Gire el anillo de ajuste en sentido antihorario para aflojar y reposicionar la cámara.
2. Atornille la antena.
3. Inserte y empuje el cargador hacia arriba en la base de la cámara.

**Nota:** Escuchará un “bip” cuando el cargador esté correctamente insertado. Si escucha esta alerta, retire el cargador presionando las pestañas de liberación y, luego, vuelva a insertarlo.

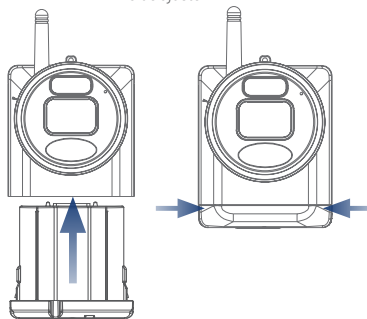
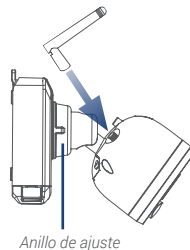



## 6 Configuración de la grabadora

1. Conecte el adaptador de corriente incluido a la grabadora.
2. Conecte la grabadora a su enrutador usando el cable Ethernet incluido.

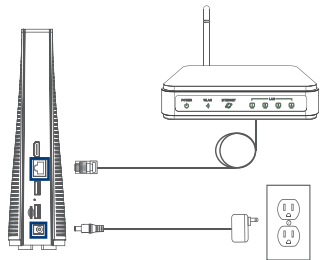

### Opcional: Configuración completa de la grabadora

1. Conecte a un monitor con el cable HDMI incluido.
2. Conecte el mouse USB incluido a uno de los puertos USB.

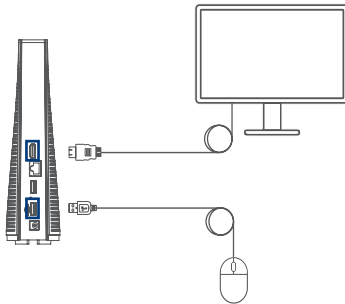



## 7 Configuración de la aplicación

1. Descargue la **aplicación Lorex Cirrus** escaneando el código QR.
2. Abra la aplicación Lorex Cirrus.
3. Pulse  para abrir el menú, luego pulse **Device List**.
4. Pulse el ícono **+**. Siga las instrucciones en la aplicación.
5. Ingrese la siguiente información, luego pulse **Save**.
  - **Media Port:** 35000
  - **Password:** 00000000
6. Aparecerá una ventana emergente que le pedirá que cambie su contraseña, pulse **OK**.
7. Siga las instrucciones en la aplicación para finalizar la configuración.



**Edit Information**

IP Address/ID  
LWFPJ933AY2U

Media Port  
35000

User Name  
admin

Password  
●●●●●●●●●●

Save



## 8 Emparejamiento de la cámara con la aplicación

1. En la pantalla de inicio, seleccione su grabadora de la lista de dispositivos.
2. Pulse cualquier canal libre marcado con un ícono .
3. Pulse **Pair**.
4. Mantenga pulsado el botón de emparejamiento en la parte posterior de la cámara hasta que las luces LED rojas dejen de parpadear y, a continuación, suelte el botón de emparejamiento. El mensaje "**Pairing success!**" aparecerá en la pantalla. Si no ve este mensaje, repita pasos 1-4.

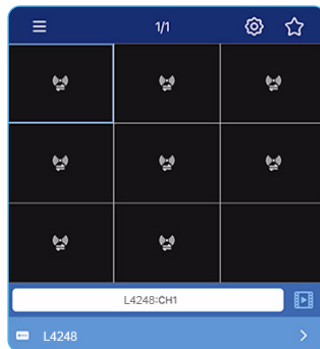

### Opcional: Emparejamiento en la grabadora

Haga clic en el ícono  de una pantalla de canal vacía. Después de presionar y mantener presionado el botón de emparejamiento en la parte posterior de su cámara, tendrá 30 segundos para emparejar la cámara.

## 9 Visualización en vivo en la aplicación

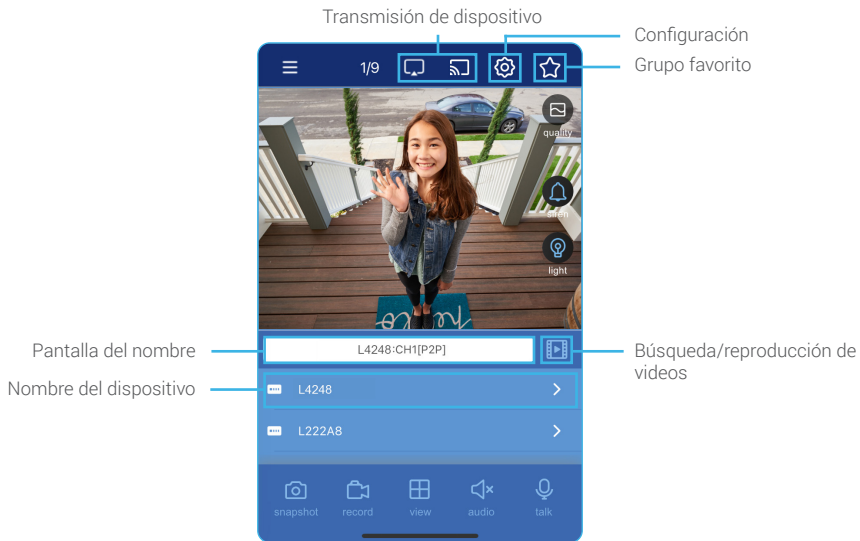



## 10 Opcional: Asistente de configuración

Cuando utilice la interfaz de la grabadora, deberá completar el Asistente de configuración de la grabadora. El asistente le ayudará a configurar los ajustes del sistema central y aparecerá cuando conecte un monitor.

Inicie sesión con el nombre de usuario del sistema (predeterminado: **admin**) y la nueva contraseña que creó al configurar la grabadora, luego, complete las instrucciones en pantalla.

Para obtener una descripción completa de los controles NVR disponibles con la configuración completa de la grabadora, vaya a [lorex.com/2K-NVR-WFCamera](http://lorex.com/2K-NVR-WFCamera).

### Uso del mouse



- **Durante la visualización de pantalla dividida:** haga clic en un canal individual para visualizarlo en pantalla completa. Haga clic nuevamente para regresar al modo de visualización de pantalla dividida.
- **Mientras se encuentra navegando en los menús:** haga clic para abrir una opción de menú



- **Durante la visualización en vivo:** haga clic en cualquier parte de la pantalla para abrir el menú rápido.
- **Mientras se encuentra navegando en los menús:** haga clic para salir de los menús.



- **Durante la visualización en vivo:** desplácese para moverse hacia arriba o hacia abajo por el contenido del menú. Mueva el cursor hacia/lejos de la parte superior de la pantalla para cerrar la barra de navegación.







## 11 Instalación de la cámara

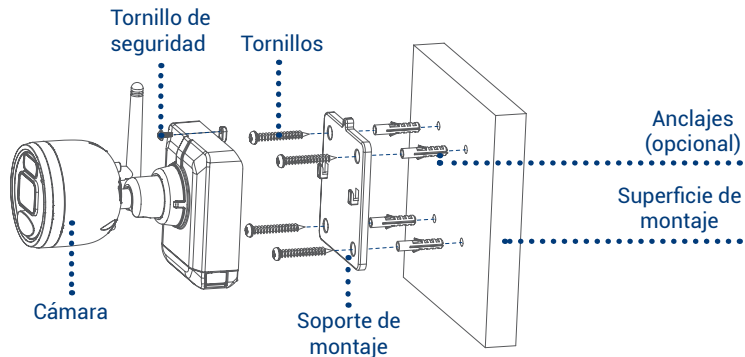

1. Coloque el soporte de montaje en la posición de montaje deseada.
2. Marque los orificios a través del soporte de montaje.
3. Con la broca incluida, taladre los orificios donde estén marcados.
4. Con el destornillador incluido, fije el soporte con los tornillos de montaje proporcionados.  
**Opcional:** Si está montando la cámara en paneles de yeso, utilice los anclajes de paneles de yeso proporcionados.





5. Alinee las ranuras de la placa de montaje de la cámara a las pestañas del soporte de montaje. Empuje y deslice hacia abajo para que esté asegurada en su lugar.
6. Inserte el tornillo de seguridad a través de los sujetadores en la parte superior de la base de la cámara y el soporte de montaje, luego ajuste el tornillo usando el destornillador.
7. Apriete el tornillo de bloqueo preinstalado usando el destornillador.

**Nota:** Para quitar el cargador en el futuro, afloje el tornillo de seguridad.

8. Ajuste el ángulo de la cámara girando el anillo de ajuste en sentido antihorario para aflojar y reposicionar la cámara.
9. Apriete el anillo de ajuste al finalizar.

*El tornillo de bloqueo preinstalado*

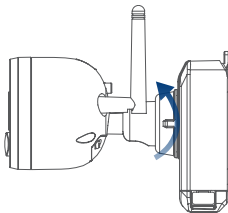
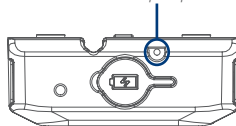



## ¿Necesita ayuda?

Visite [help.lorex.com](https://help.lorex.com) para obtener información y recursos actualizados:

- Descargue las guías de los productos
- Vea videos instructivos
- Encuentre sugerencias para la resolución de problemas y preguntas frecuentes relacionadas

## Registre su producto

Consulte nuestros [Términos de servicio completos](#) y la [Política de garantía limitada de hardware](#) en [lorex.com/warranty](https://lorex.com/warranty).



Este dispositivo cumple con la parte 15 de las normas de la FCC. El funcionamiento está sujeto a las dos condiciones siguientes: (1) Este dispositivo no puede causar interferencia dañina, y (2) este dispositivo debe aceptar cualquier interferencia recibida, lo que incluye interferencias que puedan causar un funcionamiento no deseado.

Copyright © 2021 Lorex Corporation

Debido a que nuestros productos están sujetos a mejoras continuas, Lorex se reserva el derecho de modificar el diseño, las especificaciones y los precios de los productos sin previo aviso y sin contraer ninguna obligación. Excepto errores y omisiones. Todos los derechos reservados.

*L4248-Series\_QSG\_TRILINGUAL\_R1*

